

AVI

WWW.AVI.AT

THERMOKORB[®] XII-TK

A LOAD-BEARING CONNECTOR PROVIDING THERMAL INSULATION BETWEEN INSIDE AND OUTSIDE BUILDING ELEMENTS WITH AN INCREASED INSULATION THICKNESS OF 120 MM

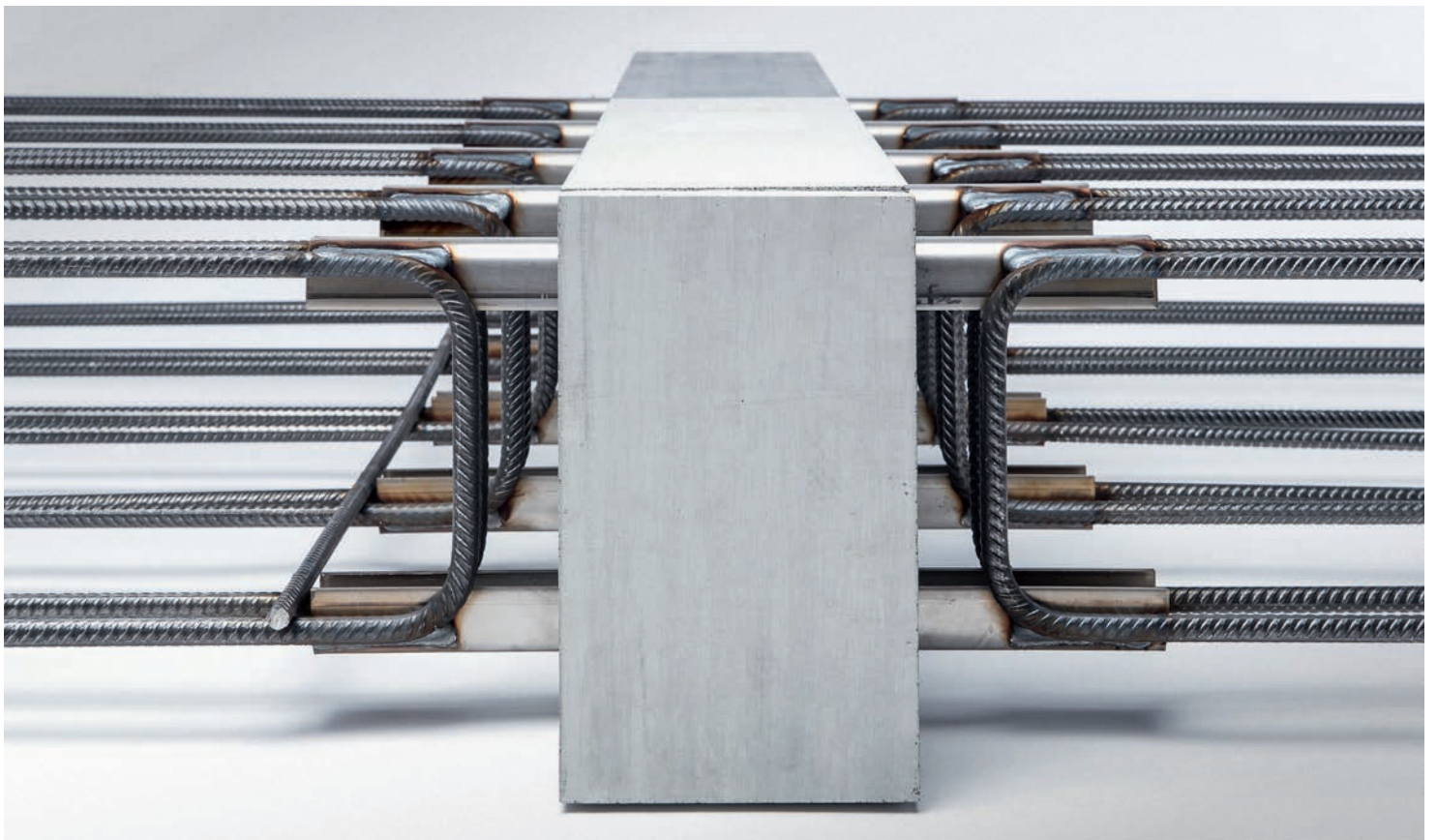



THERMOKORB® XII-TK

The insulating balcony connector Thermokorb® XII-TK is a load-bearing connecting component to be installed between reinforced concrete building elements. It improves thermal insulation at the junction of interior and exterior reinforced concrete building components. Common applications include cantilevered balconies, recessed balcony connections, corbels, parapet walls, access balconies, platforms, etc. Thermokorb® is a registered EU trade mark (no. 017792193).

Composition

A Thermokorb® XII-TK consists of a structural truss made of independent ribs and a 120 mm thick expanded polystyrene panel (EPS W30 according to EN 13163). The individual ribs pierce through the EPS panel. In order to avoid corrosion in this area, they consist of U-shaped stainless steel profiles

with stirrups made of ribbed reinforcing steel welded to their ends.

Transfer of forces from the individual ribs to the reinforced concrete building element occurs via a suitable connection reinforcement.

As a rule, all individual ribs are designed in a way that they can transfer both positive and negative bending moments and shear forces. The ribs consist of U-shaped stainless steel profiles (30 mm wide) as well as ribbed reinforcing steel stirrups, each 10 mm in diameter (B550 according to Austrian Standard ÖNORM B 4707) which are welded to the flanges of the U-profiles.

A Thermokorb® XII-TK is suitable for a building element thickness from 160 mm. The individual ribs are produced using welding robots and come in heights of 110 mm, 130 mm, 150 mm, 170 mm, and 190 mm.

TABLE OF CONTENTS

Thermokorb® XII-TK	p. 2
Calculation software Thermotool	p. 3
Thermokorb® XII-TK overview	p. 4
Designation system of Thermokorb® XII-TK	p. 5
Type series: TKM	p. 6
Type series: TKF	p. 11
Type series: TKA	p. 12
Type series: AT	p. 16
Thermokorb® XII-TK installation cases, ground plans	p. 17
Thermokorb® XII-TK load-bearing behaviour	p. 18
Moments and shear forces	p. 18
Interaction diagrams	p. 20
Recommended additional camber	p. 23
Standard type	p. 24
Rib type	p. 25
Building physics – thermal insulation values	p. 26
Expansion joint spacings	p. 28
Thermokorb® XII-TK at a building corner	p. 28
Installation instructions	p. 29
Overview product family Thermokorb®	p. 30

Cross Sectional Height of a Single Rib Element

BCT* (mm)	≥ 160	≥ 180	≥ 200	≥ 220	≥ 240
Rib Height RH (mm)	110	130	150	170	190

* Building Component Thickness

Application

On account of its multiaxial strength, Thermokorb® XII-TK is appropriate for numerous applications.

For the use in slab-type structures with predominately moment and/or shear loading (M_{Ed} , V_{Ed}), standard elements of the XII-TKM and XII-TKA series with a uniform length of 1000 mm and varying number of ribs (2–10 ribs) are provided (see page 24, standard type).

For narrow spaces, however, it is also possible to produce elements with a uniform minimum rib spacing of 100 mm ("rib type"). Hence the element length depends on the number of ribs (see page 25, rib type).

The forces are transferred from the stainless steel profiles to the reinforced concrete through welded-on stirrups made of ribbed reinforcing steel of steel grade B550. The 10 mm bar diameter that is used uniformly corresponds optimally to the load bearing capacity of the stainless steel profiles and, at the same time, it determines the connection reinforcement to be provided on construction site.

Low deformation and good vibration behaviour are achieved by Thermokorb® XII-TK elements because the individual ribs have a high moment of inertia. The additional camber for cantilevered slabs, therefore, can be very small. The load bearing capacity of the ribs depends on the rib height. The rib height and building component thickness can be matched according to requirements and application. The difference between building component thickness and rib height should not be less than 50mm in order to ensure sufficient concrete cover.

Fire protection class

Without additional fire-proofing panels, Thermokorb® XII-TK elements are classified as R60. For higher fire protection requirements (REI120), fire-proofing panels are glued onto the top and bottom. The lateral balcony closures (open faces at the ends of the thermal separation) have to be carried out with lateral fire protection panels for fire protection requirement REI120. In the case of surrounding fire protection panels, the Thermokorb® XII-TK is designated REI120-U.

Properties of Thermokorb® XII-TK:

- The Thermokorb® XII-TK is characterised by high product stability.
- The double-symmetrical design ensures safe installation.
- The Thermokorb® XII-TK is available in the fire protection versions R60, REI120 and REI120-U.
- The high moment of inertia of the individual ribs has a very favourable effect on the deformation and vibration behaviour.
- In the area of the Thermokorb® XII-TK stirrups, no additional edge stirrups are usually necessary.
- The required on-site connection reinforcement is limited to 2ø10 per rib, which provides full moment capacity.
- The Thermokorb® XII-TK can be used universally for multi-axial loading (e.g. for connections of walls, beams, or corbels).
- The Thermokorb® XII-TK is available as standard and rib type.



All information about the Thermokorb® XII-TK is available at our website www.avi.at

CALCULATION SOFTWARE THERMOTOOL



The calculation software Thermotool enables the user to dimension all Thermokorb® types. The software consists of various modules that facilitate the calculation of thermal separations for common fields of application. The Thermotool software uses the finite element method to determine moments and shear forces. For the design, the relevant internal forces are determined individually for each Thermokorb.



Our design software is available for download on our website www.avi.at

THERMOKORB® XII-TK OVERVIEW

CANTILEVERED BALCONY SLAB

XII-TKM (from page 6)

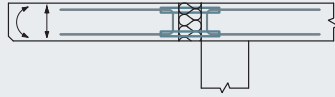

SUPPORTED BALCONY/RECESSED BALCONY

XII-TKA (from page 12)

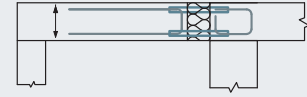

BALCONY CONNECTION - WALL BELOW (WU)

XII-TKM special form (page 9)

XII-TKA V1 + V2 (page 13)

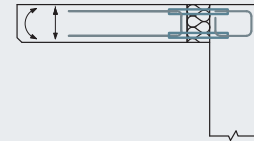
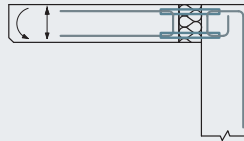

BALCONY CONNECTION WALL ABOVE (WO)

XII-TKM special form (page 9)

XII-TKA V1 + V2 (page 13)

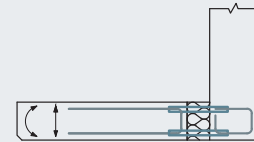
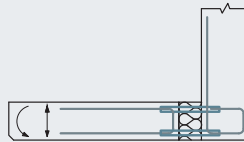

BALCONY CONNECTION - ROOF ABOVE (DO)

XII-TKM special form (page 8)

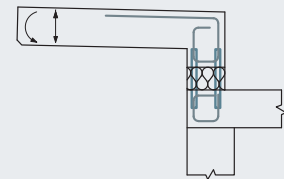

LEVEL CHANGE UPWARDS (NO)

XII-TKM special form (page 10)

XII-TKA V1 + V2 (page 14)

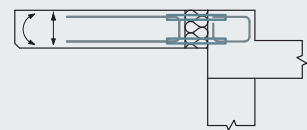
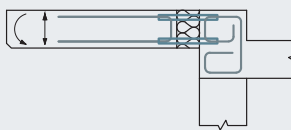

LEVEL CHANGE DOWNWARDS (NU)

XII-TKM special form (page 10)

XII-TKA V1 + V2 (page 14)

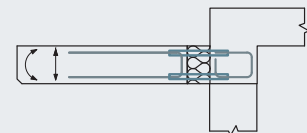
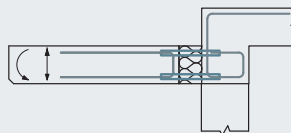

CANTILEVERED BALCONY SLAB WITH PRECAST CONCRETE ELEMENTS (HALF SLAB)

XII-TKF (page 11)

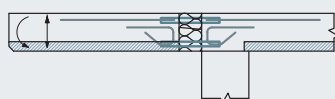

PARAPET IN FRONT OF SLAB WITH XII-TKA

XII-TKA V0+V1+V2 (page 14)

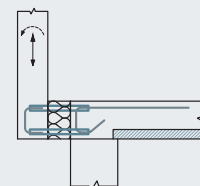

WALLS, BEAMS AND CORBELS
XII-TKM and XII-TKA
 (page 15)

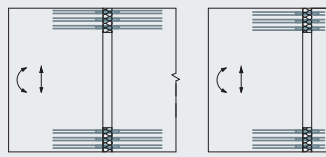

PARAPET WALL ELEMENT
XII-AT 2 (page 16)

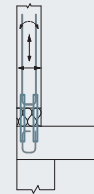

DESIGNATION SYSTEM OF THERMOKORB® XII-TK

To describe a Thermokorb® XII-TK correctly, use the designation system in the table below. The type, the number of ribs, the shape of the stirrups outside and inside, the rib height, the insulation height, and the fireproofing rating can be selected. Additional options are elements used for walls with the additional designation -W (see page 15), rib-type elements with the additional designation R (see page 25), and the design as a special shape (see pages 8, 9 and 10) with the additional designation SF.

Standardised “AVI special shapes” can be used for well-established connection geometries common in building construction.

“Free special shapes” can be coordinated with the Technical Service of AVI as required and possible. If the selected insulation body height differs by more than 50 mm from the rib height, the necessary additional insulation is attached symmetrically. This means the additional insulation on top (=ZDO) has the same thickness as the additional insulation on the bottom (=ZDU). The fire protection panels (BSP) are always provided on the outside as standard. If a different distribution of the additional insulation is required, it must be specified at the end of the designation, e.g. ZDO = 2 cm, ZDU = 1 cm. Further information on the additional insulation can be downloaded from the website www.avi.at.

XII-TKM-W R5 G-G 15/20 R60

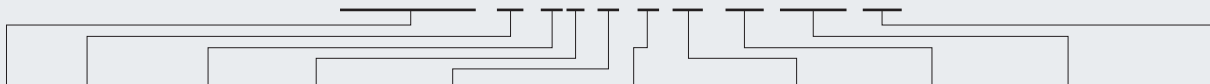

Type	Element for Walls	Rib Type	Number of Ribs	Stirrup Shape Outside ²	Stirrup Shape Inside ²	Rib Height	BCT* or Insulation Height	Fire Proofing	Designation of Special Shape ¹
		“empty”=length of element 1 m R=element length depends on number of ribs	n	G = straight E = bent up SF = special shape V0/V1/V2 see XII-TKA	G = straight E = bent up SF = special shape V0/V1/V2 see XII-TKA	RH (cm)	D (cm)		AVI special shape Free special shape (cm)
XII-TKM	-/-W	-/R	1-10	G/E/SF/	G/E/SF/	11/13/15/17/19	≥ 16/18/20/22/24	R60/REI120/REI120-U	WU/WO/DO/NO/NU/SF (dimensions)
XII-TKA	-/-W	-/R	1-10	G/E/SF/ V0/V1/V2	G/E/SF/ V0/V1/V2	11 (V0) for V1 or V2: 11/13/15/17/19	≥ 16/18/20/22/24	R60/REI120/REI120-U	WU/WO/DO/NO/NU/SF (dimensions)
XII-TKF	-	-/R	1-10	E	E	13/15/17/19	≥ 18/20/22/24	R60/REI120/REI120-U	-
XII-AT	-	-	2	G/SF/ V1/V2	G/SF/ V1/V2	11/13/15/17/19	≥ 16/18/20/22/24	R60/REI120/REI120-U	SF

* Building Component Thickness

Examples: XII-TKM R6 G-E 15/20 REI120 XII-TKM 7 G-SF 15/20 REI120 NO (14 x 34) XII-TKF 9 E-E 13/18 R60
 XII-TKA 4 G-V1 11/18 R60 XII-TKA 5 G-V2 13/18 R60 XII-AT 2 G-V1 11/16 REI120

¹ The designations to be used for the free special shapes and the standardised AVI special shapes with the respective dimensions can be found in the current overview on our website in the “product brochures” download area.
² Stirrup shape: The stirrups on at least one side of the standard version (inside or outside) are stirrup types G or E (XII-TKM), or V0, V1 or V2 (XII-TKA).

TYPE SERIES: XII-TKM

Thermokorb® XII-TK for Transferring Moments and Shear Forces

DESCRIPTION

The XII-TKM series is primarily used to transfer bending moments and shear forces (interaction). In the case of applied forces with changing signs, the use of XII-TKM G-G ribs is required. XII-TKM E-E ribs or XII-TKM G-E ribs are used in precast slabs (half slabs) to prevent the compression chord made of ripped steel from colliding with the precast slab (see Fig. 4). The design forces and the interaction diagrams for the rib heights 110 to 190 mm are provided on pages 18 to 22.

Main application areas:

- Freely cantilevered balcony slabs
- Continuous slabs (indirect support)
- Special purpose solution: e.g. level changes, connections of cantilevered slabs to walls, wall connections

Reinforcement provided on site:

The on-site connection reinforcement should transfer the forces acting in the $\varnothing 10$ mm stirrups, e.g. 2 $\varnothing 10$ mm (B550) per rib for the tensile reinforcement. In the standard application (G-stirrups), the XII-TKM stirrups can be used as edge reinforcement.

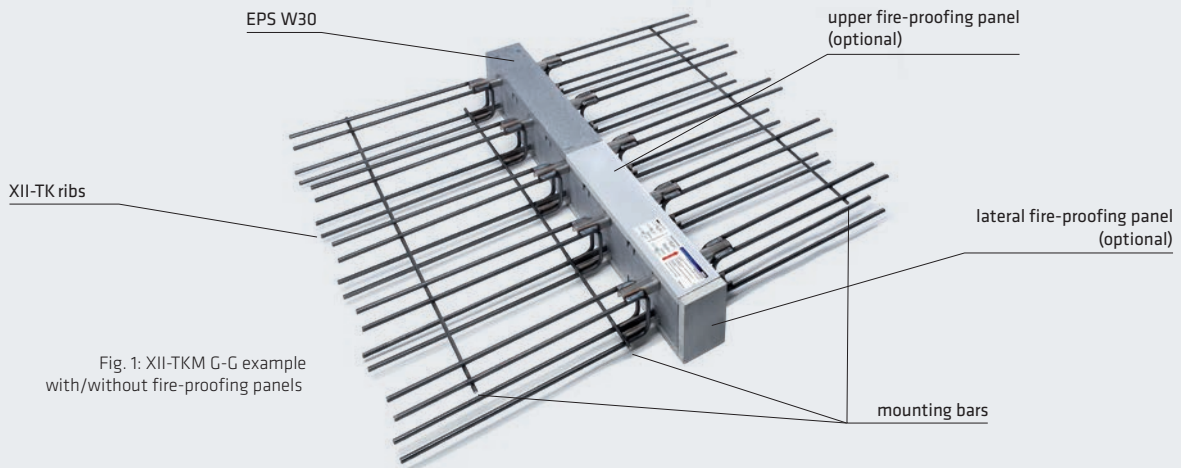

Fig. 1: XII-TKM G-G example with/without fire-proofing panels

TYPES OF STANDARD RIBS

The bottom stirrup leg is available in two variants:

- G ... straight (also for applied forces with changing signs)
- E ... bent up (e.g. for precast half slabs)

XII-TKM G-G RIBS

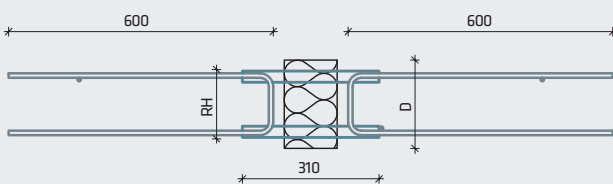

XII-TKM G-E RIBS

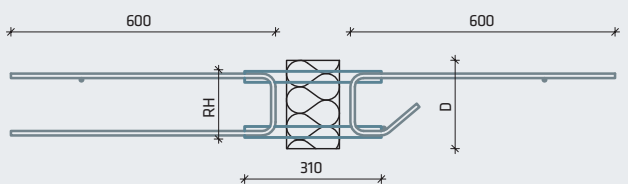

Fig. 2: Types of ribs of the type series XII-TKM

Special stirrup shapes different from the XII-TKM series are always possible (see XII-TKM special rib shapes on pages 8, 9 and 10).

INSTALLATION CASES WITH XII-TKM STANDARD RIBS

Cantilevered balcony slab -

External wall with composite heat insulation system

In this installation example, the insulating body of the Thermokorb® XII-TK is located outside of the wall and connects with the composite heat insulation system.

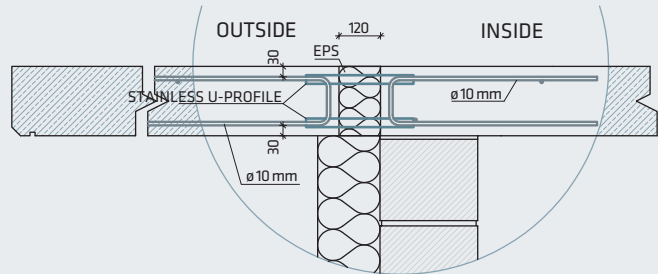

Fig. 3: Cantilevered balcony slab with XII-TKM G-G rib

Cantilevered balcony slab -

External wall without composite heat insulation system

In this installation example, the insulating body of the Thermokorb® XII-TK is located within the wall. In this example, the inside slab is a precast half slab.

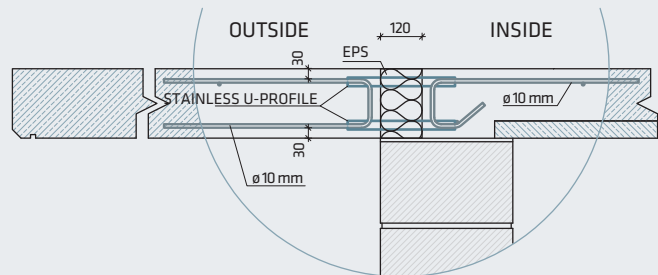

Fig. 4: Cantilevered balcony slab with XII-TKM G-E rib

The bottom stirrup leg of the XII-TKM G-E rib is bent up to avoid a collision with the precast slab element.

Balcony with small level change downwards

A standard element with a XII-TKM G-E rib can also be used for a level change with a small height difference downwards, provided that the condition $\Delta_{h,a} \leq h_i - c_i - c_a - d_s$ is observed.

CONDITION OF APPLICATION

$$\Delta_{h,a} \leq h_i - c_i - c_a - d_s$$

EXAMPLE:

$$h_i = 200; c_i = 30; c_a = 30; d_s = 10; \Delta_{h,a} = 70 \text{ mm}$$

$$\Delta_{h,a} = 70 \text{ mm} \leq h_i - c_i - c_a - d_s = 200 - 30 - 30 - 10 = 130 \text{ mm}$$

$$70 \text{ mm} \leq 130 \text{ mm} \checkmark$$

The minimum width b_{min} depends on the level change $\Delta_{h,i}$ (inside).

$$\Delta_{h,i} \leq 50 \text{ mm} \rightarrow b_{min} = 200 \text{ mm}$$

$$\Delta_{h,i} > 50 \text{ mm} \rightarrow b_{min} = 220 \text{ mm}$$

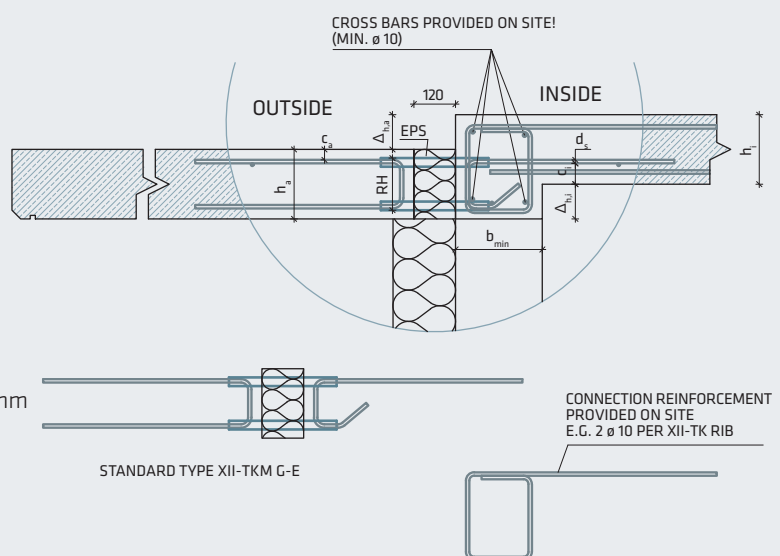

Fig. 5: Balcony with small level change downwards with XII-TKM G-E rib

INSTALLATION CASES WITH XII-TKM SPECIAL SHAPES

Thermokorb® special shapes offer the possibility of connecting balconies and projecting roofs to walls, or to slabs in the area of height differences, whereby less on-site reinforcement is usually required than for the solution with the XII-TKA series.

The same basic design rules apply to the special shapes as to the XII-TKM standard ribs (see pages 18 to 22).

“AVI special shapes” are special shapes with predefined stirrup dimensions for common connection geometries widely used in building construction. “Free special forms” enable a customer-specific design of the welded-on reinforcement stirrups within the scope of the manufacturing possibilities. On request, free special shapes can be coordinated with the support of AVI.

A current overview of the AVI special shapes with predefined dimensions can be found on our website in the “product brochures” download area.



All Informationen about AVI products can be found on our website www.avi.at

Note: When connecting with special shapes, the thickness of the continuing member must always be taken into account. If the thickness of the continuing member is less than the thickness of the connected member, the load-bearing capacity of the connection must be adjusted if necessary.

Balcony connection - roof above (DO)

Free special shape for the connection of a cantilevered slab e.g. a projecting roof

$b_1 \leq 600 \text{ mm}$

$d \leq 750 \text{ mm}$

b_2 defines the inclination of the stirrup leg

Note: The vertical concrete portion, including the insulating body and the inside slab, is generally not to be regarded as a beam. It is recommended to calculate the “outside” and “inside” structural systems separately.

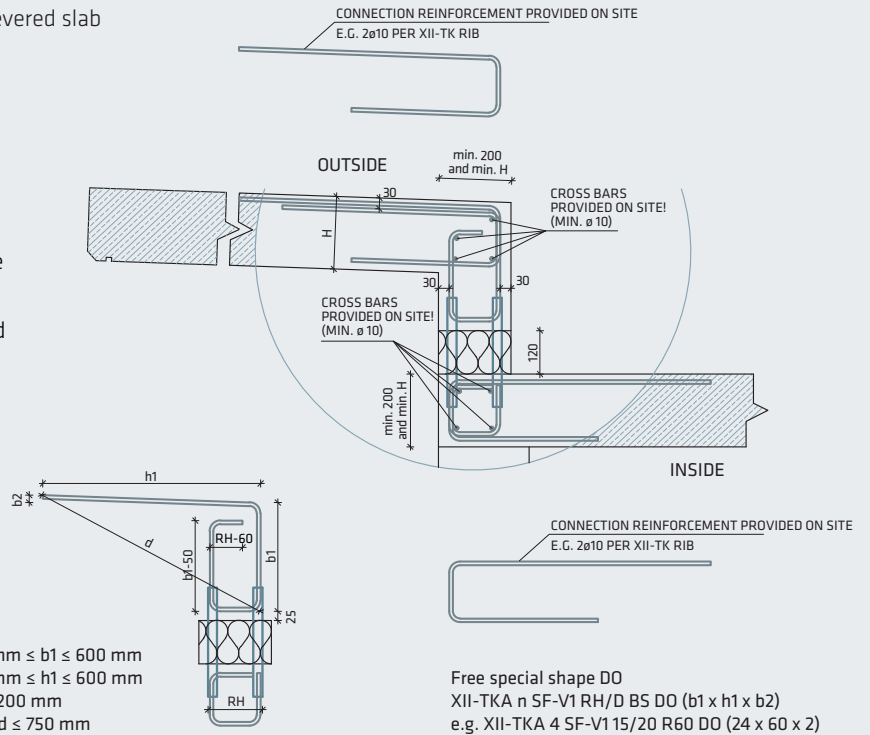
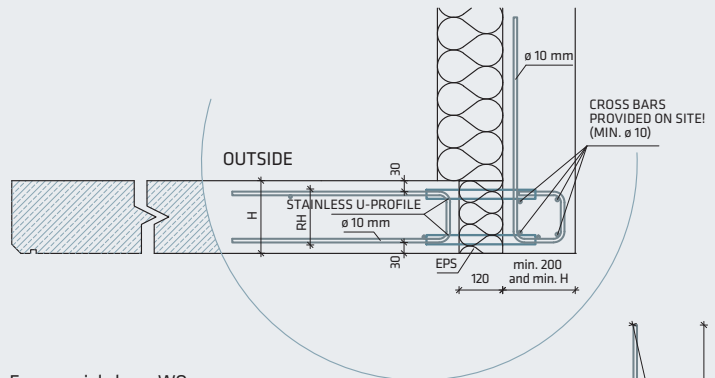
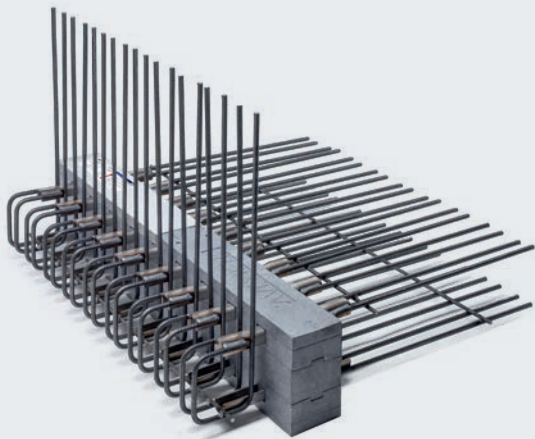

Fig. 6: Balcony connection – roof above with free special shape DO

Balcony connection - wall above (WO)

Free special shape for a cantilevered slab connected to a wall, where the stirrup is bent upwards.

(Version up to 5 ribs per 1 m cage are also possible with XII-TKA V1 or V2 - see page 13)



Free special shape WO
 XII-TKM n G-SF RH/D BS WO (b1 x h1)
 e.g. XII-TKM 6 G-SF 15/20 REI120 WO (29 x 60)

140 mm ≤ b1 ≤ 600 mm
 (RH-10 mm) ≤ h1 ≤ 600 mm
 with d ≤ 750 mm

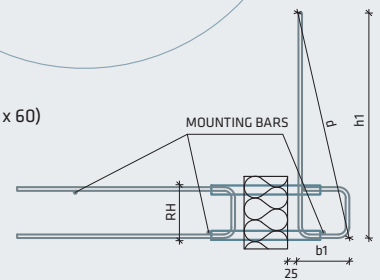
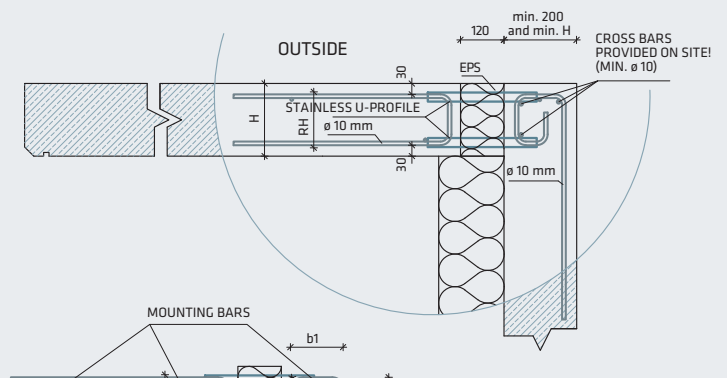
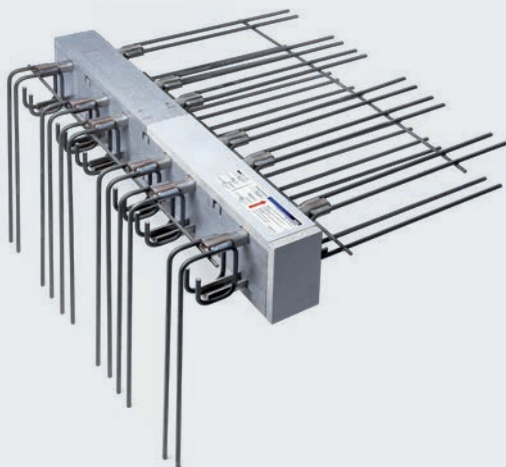

Fig. 7: Balcony connection - wall above with free special shape WO

Balcony connection - wall below (WU)

Free special shape for a cantilevered slab connected to a wall, where the stirrup is bent downwards.

(Version up to 5 ribs per 1 m cage are also possible with XII-TKA V1 or V2 - see page 13)



Free special shape WU
 XII-TKM n G-SF RH/D BS WU (b1 x h1)
 e.g. XII-TKM 6 G-SF 15/20 REI120 WU (29 x 60)

140 mm ≤ b1 ≤ 600 mm
 100 mm ≤ h1 ≤ 600 mm
 with d ≤ 750 mm

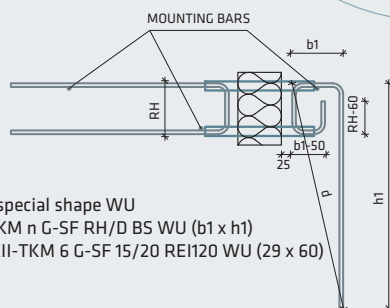

Fig. 8: Balcony connection - wall below with free special shape WU

Balcony with level change upwards (NO)

Free special shape for a balcony with upward level change.
 (Version up to 5 ribs per 1 m cage are also possible with XII-TKA V1 or V2 - see page 14)

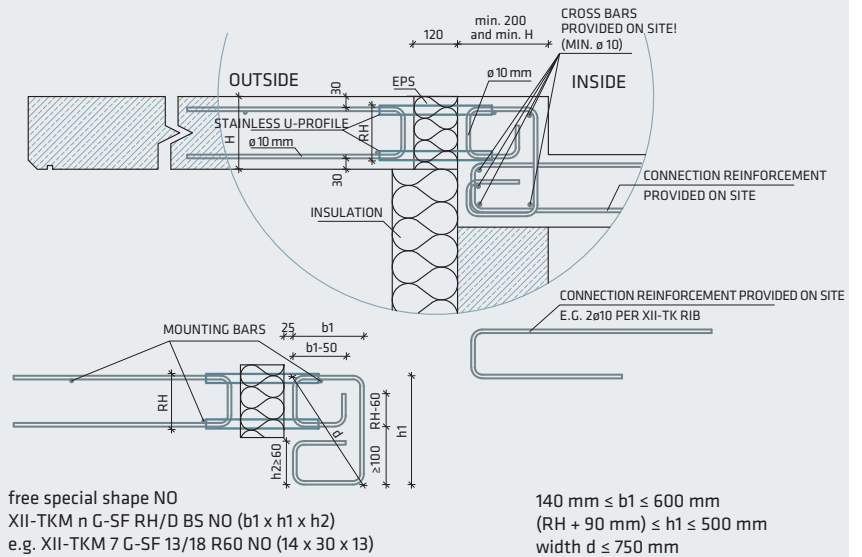
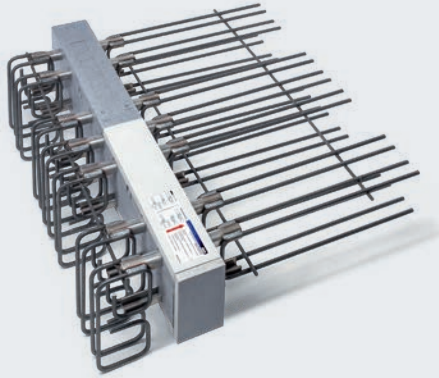

Fig. 9: Balcony connection – balcony with upward level change with free special shape NO

Balcony with level change downwards (NU)

Free special shape for a balcony with downward level change.
 (Version up to 5 ribs per 1 m cage are also possible with XII-TKA V1 or V2 - see page 14)

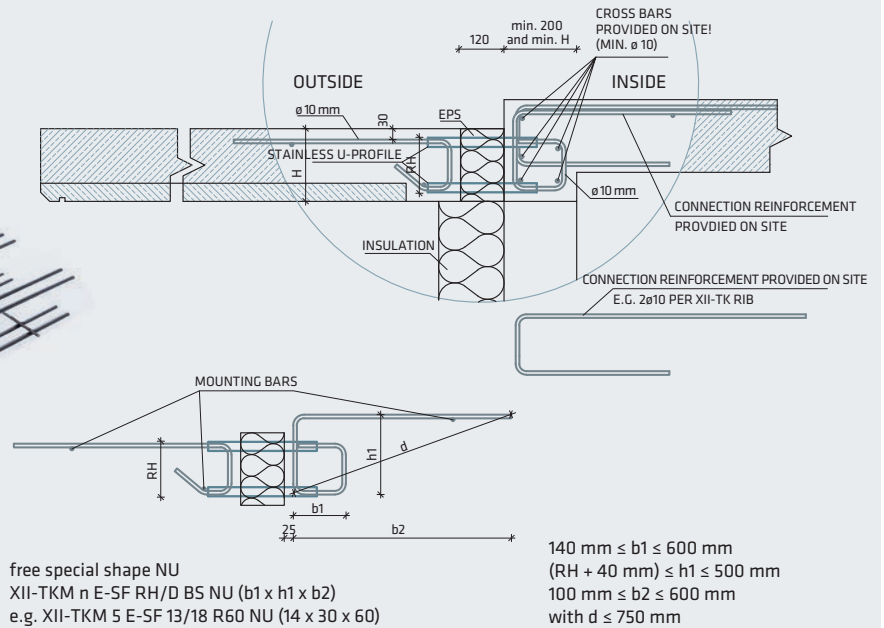
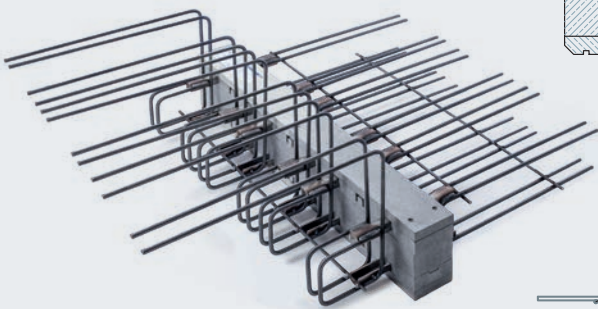

Fig. 10: Balcony connection – balcony with downward level change with free special shape NU

TYPE SERIES: XII-TKF

Thermokorb® XII-TK for Transferring Moments and Shear Forces for Precast Slab Elements as a Split Element

DESCRIPTION

The type series XII-TKF is primarily used for freely cantilevered balcony slabs – in a split design especially for the requirements of the precast concrete industry (precast slab elements). One part (compression chord) is installed in the precast slab element in the concrete factory, the second part (tension chord) is then put in place on construction site. The minimum slab thickness is 180 mm. The design values of the applied forces and the interaction diagrams for the rib heights 130 to 190 mm are given on pages 19, 21 and 22. It should be noted that the type series XII-TKF only has 50% of the shear capacity of the XII-TKM type series. In the interaction diagrams, these shear capacities are given on the right-hand side.

Main application area:

- freely cantilevered balconies made of precast elements

Reinforcement provided on site:

The on-site connection reinforcement should transfer the forces acting in the $\varnothing 10$ mm stirrups, e.g. 2 $\varnothing 10$ mm (B550) per rib for the tensile reinforcement.

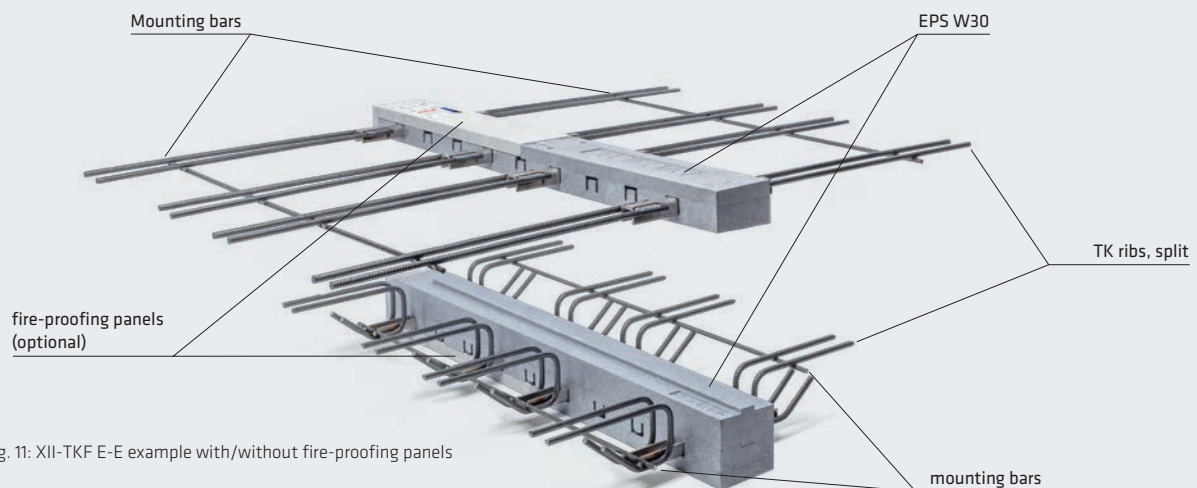

Fig. 11: XII-TKF E-E example with/without fire-proofing panels

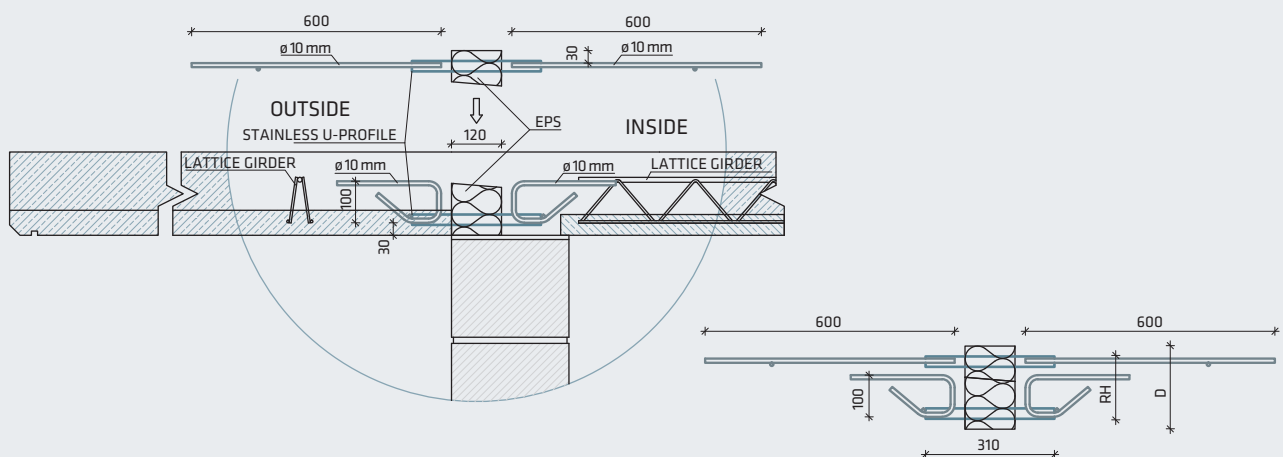

Fig. 12: Cantilevered balcony slab with split XII-TKF E-E rib

e.g. XII-TKF 4 E-E 13/18 R60

TYPE SERIES: XII-TKA

Thermokorb® XII-K Primarily Used for Transferring Shear Forces

DESCRIPTION

The type series XII-TKA is primarily suitable for transferring shear forces for applications in supported balconies, recessed balconies, parapet walls and various connections of precast elements. Installation of the XII-TKA V1 or V2 type series also enables the transfer of bending moments and shear forces for level changes and cantilevered slabs connected to walls (up to max. 5 ribs per 1 m element). Appropriate stirrup reinforcement must be provided on site (see Fig. 15 to 19). For higher loads, we recommend the XII-TKM special shapes. The design values of the applied forces and the interaction diagrams for rib heights from 110 to 190 mm are given on pages 18 to 22.

Main application areas:

- Supported balconies
- Recessed balconies
- Protruding parapets
- Parapet walls
- Special solutions: e.g. level changes, balcony connections to walls, wall connections

Reinforcement provided on site:

As further connection reinforcement, at least two stirrups with a diameter of 10 mm (B550) per rib are recommended for the application of the XII-TKA V1 or V2 as a special solution, especially in the case of flexural loading. The exact design of the continuing reinforcement is shown in Figures 15 to 19.

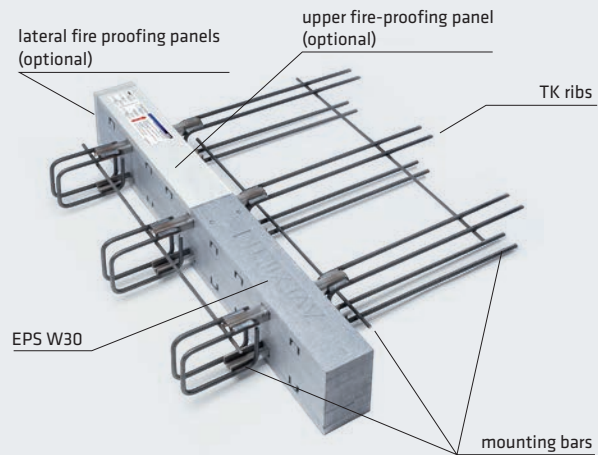

Fig. 13: XII-TKA G-V2 example with/without fire-proofing panels

TYPES OF STANDARD RIBS

The bottom stirrup leg is available in two variants:

G ... straight (also for applied forces with changing signs)

E ... bent up (e.g. for precast floor slabs)

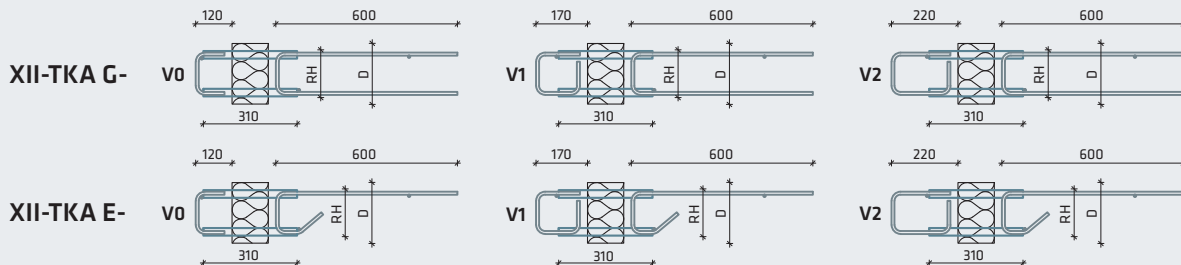

Fig. 14: Rib types of the type series XII-TKA

Special stirrup shapes deviating from the XII-TKA series can be individually coordinated with the Technical Service of AVI. When using the XII-TKA series, it should be noted that the V0 type is only available with a rib height of 110 mm. An adequate design value for bending and shear resistance in the connected reinforced concrete members must be ensured by a structural design engineer according to EC2.

INSTALLATION CASES WITH XII-TKA RIBS

For the use of XII-TKA ribs in the V1 or V2 design for special solutions, the design fundamentals found on pages 18 to 22 must be applied.

Balcony connection - wall below (WU)

The types XII-TKA V1 or V2 are used for a balcony connected to a wall with up to max. 5 ribs per 1 m element.

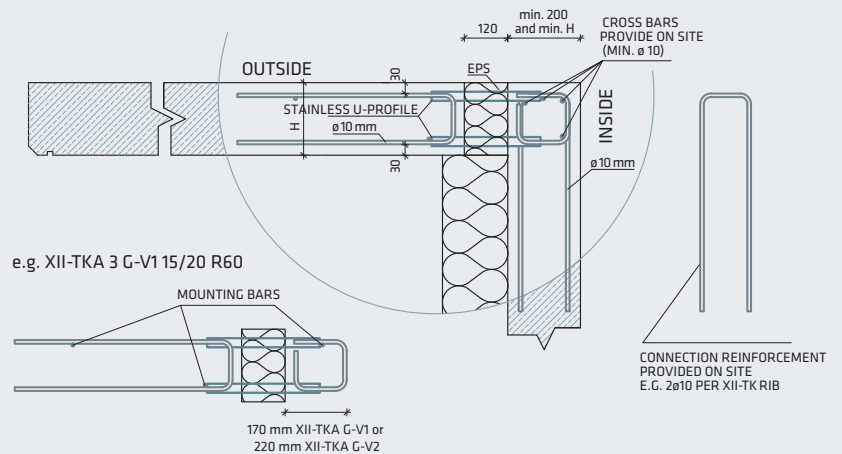

Fig. 15: Balcony connection – wall below with XII-TKA G-V1 or V2

Balcony connection - wall above (WO)

The types XII-TKA V1 or V2 are used for a balcony connected to a wall with up to max. 5 ribs per 1 m element.

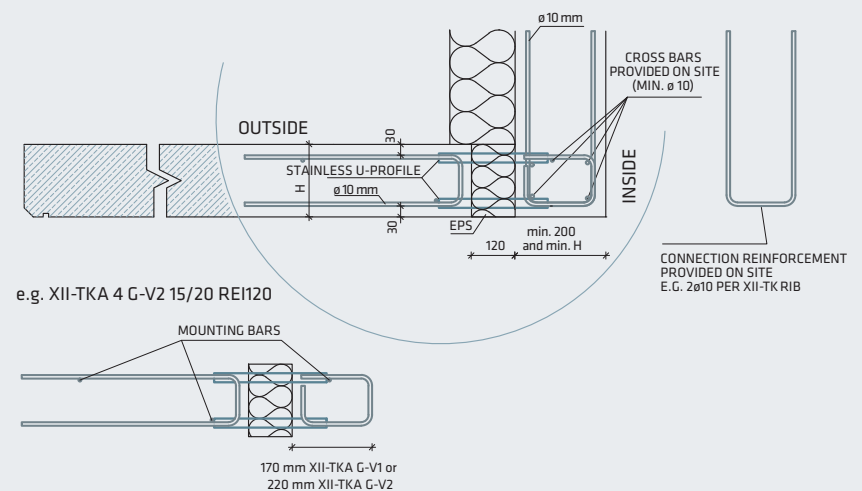

Fig. 16: Balcony connection – wall above with XII-TKA G-V1 or V2

Recessed balcony

The XII-TKA as a shear force element e.g. for a recessed balcony.

*Options:

Variant V0: 120 mm

Variant V1: 170 mm

Variant V2: 220 mm

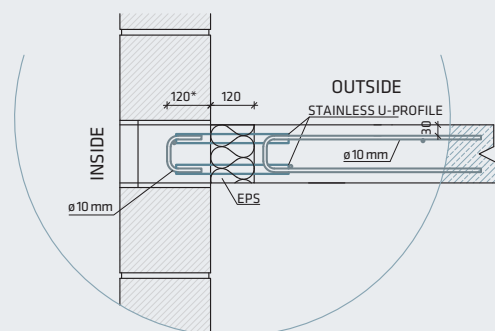

Fig. 17: Recessed balcony XII-TKA G-V0 Rib

Balcony with level change upwards (NO)

The types XII-TKA V1 or V2 are used for a balcony with a level change with up to max. 5 ribs per 1 m element.

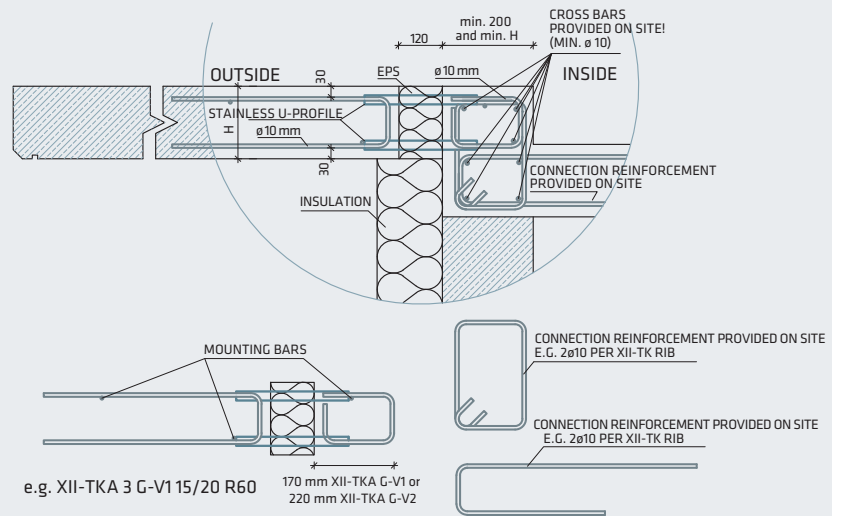

Fig. 18: Balcony with level change upwards with XII-TKA G-V1 or V2

Balcony with level change downwards (NU)

The types XII-TKA V1 or V2 are used for a balcony with a level change with up to max. 5 ribs per 1 m element.

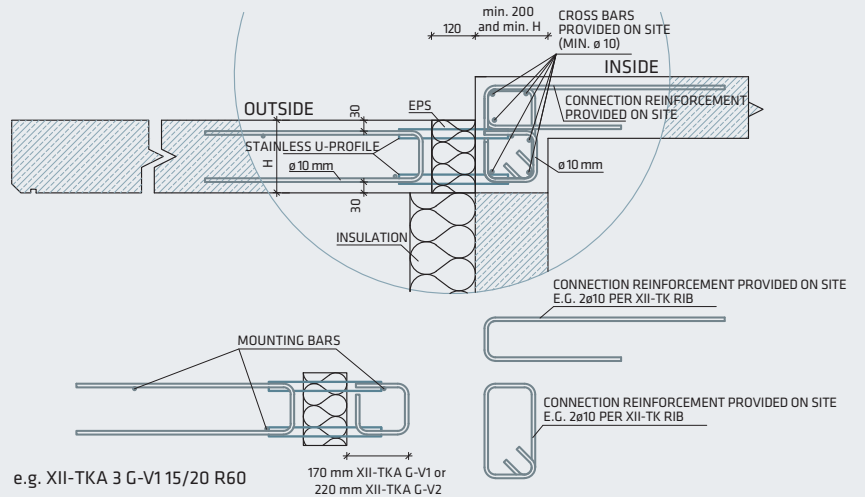

Fig. 19: Balcony with level change downwards with XII-TKA G-V1 or V2

INSTALLATION CASE WITH XII-TKA V0 RIBS

Parapet in front of slab

This example shows a XII-TKA for a parapet in front of a slab with on-site stirrup reinforcement. When connecting the parapet to a prefabricated slab, a XII-TKA V0-E rib is used.

*Options:

- Variant V0: 120 mm
- Variant V1: 170 mm
- Variant V2: 220 mm

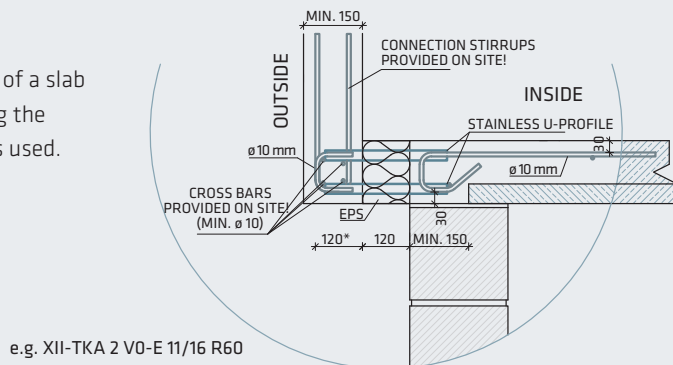

Fig. 20: Parapet in front of slab with XII-TKA V0-E rib

WALL CONNECTION

When arranged vertically, the Thermokorb® XII-TK can also be used for shear walls. The Thermokorb® XII-TK is mainly installed at the upper and lower end of the shear wall. Depending on the load and effective height of the shear wall, the Thermokorb® XII-TK can also be distributed over the entire height.

When choosing the rib height of the Thermokorb® XII-TK, the reinforcement layout in the wall must be taken into account. Depending on the position of the continuing reinforcement, it may be necessary to reduce the rib height of the Thermokorb® XII-TK.

If a Thermokorb® XII-TK is intended in a vertical arrangement for a shear wall, the type designation of the Thermokorb® XII-TK is supplemented with “-W” (W...wall element) (e.g. TKM-W 4 G-G 15/22 R60).

The composition of the Thermokorb® XII-TK in the “wall element” version corresponds to the standard element. Only the name and the placement of the label change to ensure correct installation.

Wall elements with increased fire protection requirements are always designed with all-round fire protection panels (REI120-U).

WALL CONNECTION WITH XII-TKA AND XII-TKM

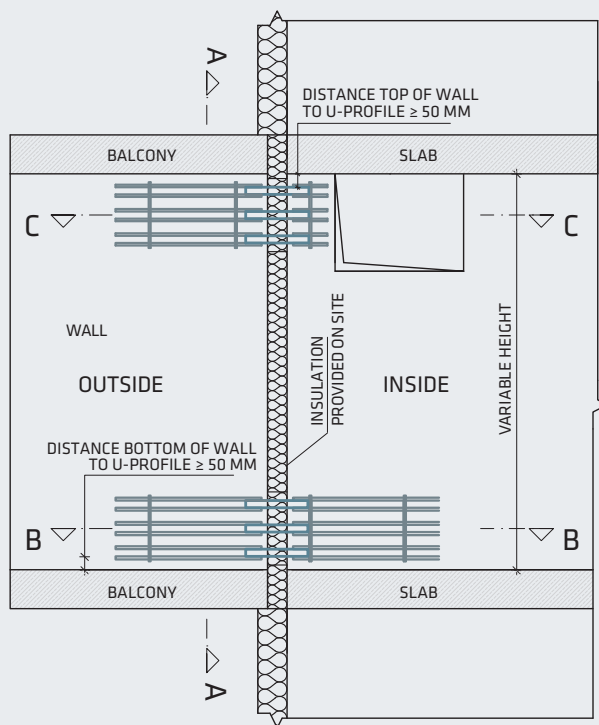

SECTION A-A

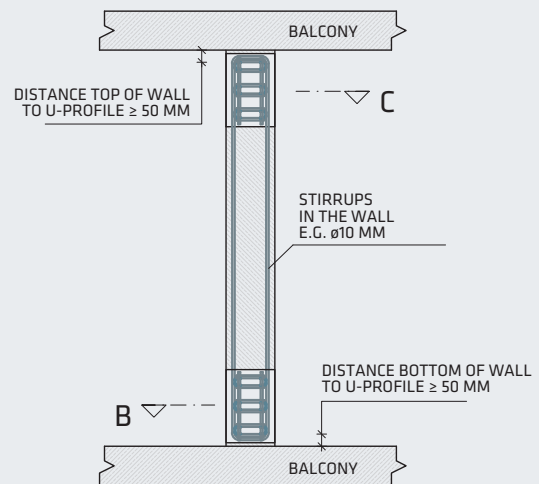

SECTION B-B

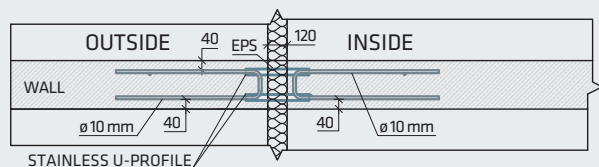

SECTION C-C

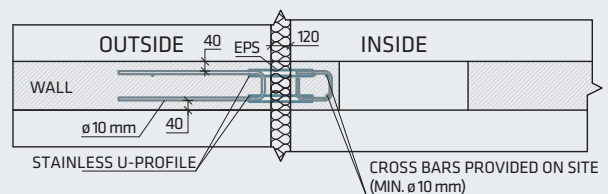

Fig. 21: Wall connection with XII-TKM G-G rib and XII-TKA G-V1 rib (elevation and sections)

TYPE SERIES: XII-AT

Thermokorb® XII-TK Especially For The Use In Parapet Walls

DESCRIPTION

The Type XII-AT is a load bearing connector providing thermal insulation and is used for the transfer of axial forces, shear forces and bending moments between parapet walls and floor slabs. The distance between elements is chosen according to the structural requirements and can be determined using the design program "Thermotool". The

thermal insulation between adjacent Thermokorb elements must be provided on site. Type XII-AT is available from a rib height of 110 mm in the version shown in Fig. 22 (two ribs, element length 300 mm, V1 or V2). The minimum thickness of the parapet wall is 160 mm.

Main application area:

- Parapet walls

Reinforcement provided on site:

The on-site connection reinforcement should transfer the forces acting in the $\varnothing 10$ mm stirrups, e.g. $2\varnothing 10$ mm (B550) per rib for the tensile reinforcement.

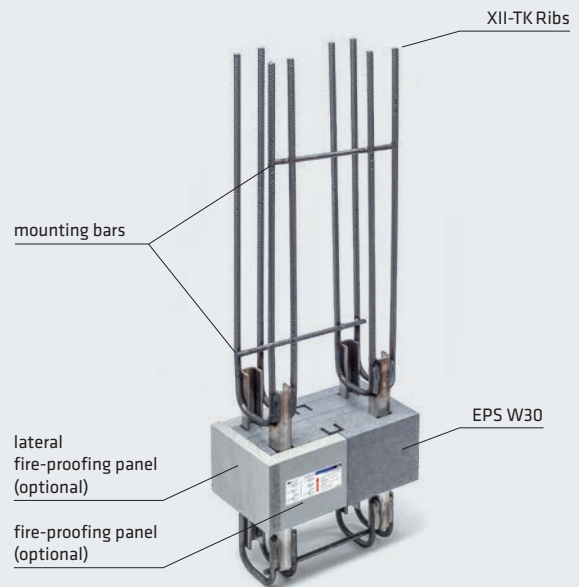

Fig. 22: XII-AT 2 example with/without fire-proofing panels

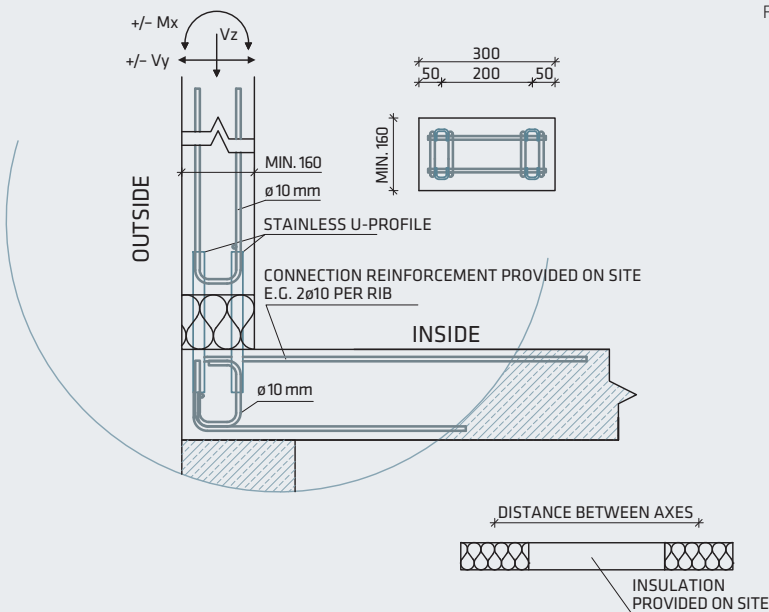

Fig. 23: Use of type XII-AT 2 for a parapet connection

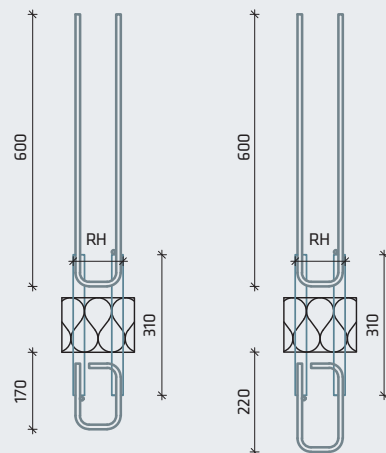
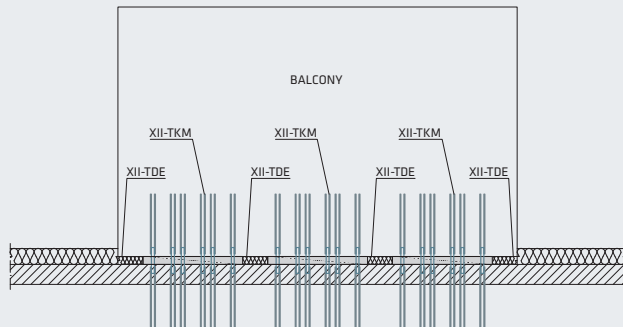

Fig. 24: XII-AT 2 G-V1 and V2

THERMOKORB® XII-TK INSTALLATION CASES, GROUND PLANS

Cantilevered rectangular balcony with XII-TKM and XII-TDE

- Standard application for cantilevered balconies



Recessed balcony with XII-TKM, XII-TKA and XII-TDE

- Applied for recessed balconies with large dimensions to reduce deformation
- Transfer of large concentrated loads at the outer end of the balcony with the XII-TKA
- Linear support on the building side with XII-TKM

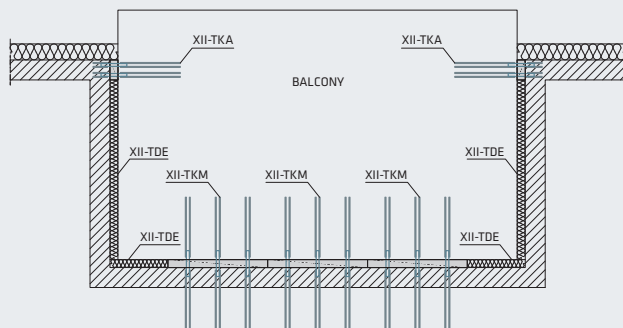

Inner corner balcony with XII-TKM, XII-TKA and XII-TDE

- Combined application with XII-TKM and XII-TKA

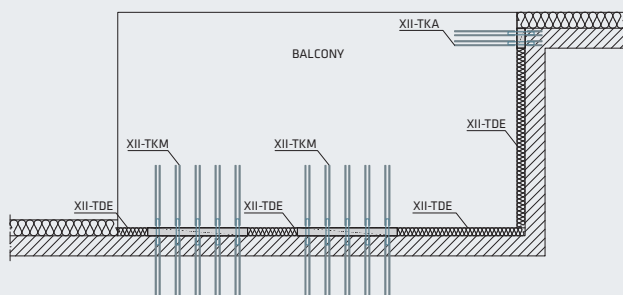

Outer corner balcony with XII-TKM and XII-TDE

- In the case of high shear loads in the corner area, Shear Reinforcement Elements **QE** and Punching Shear Reinforcement **DE+DKD** can be used

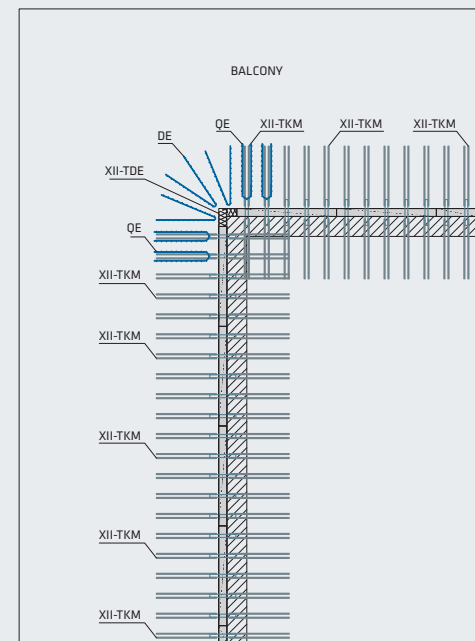

All information about the AVI products can be found on our website www.avi.at

THERMOKORB® XII-TK LOAD-BEARING BEHAVIOUR

Transfer of bending moments is accomplished by transferring the tensile and compression force via reinforcement stirrups to the upper and lower U-profile and from here via the reinforcement stirrups into the adjacent concrete member. The shear force is transferred via local bending of the individual U-profiles. It is divided equally between both U-profiles. The structural boundary conditions

result in a mutual dependency of moment resistance and shear resistance and, therefore, a maximum moment resistance $M_{Rd,max}$ with the associated shear resistance V_{Rd} and a maximum shear resistance $V_{Rd,max}$ with the associated moment resistance M_{Rd} . This applies to positive and negative shear forces ($+/-V_{Ed}$) and moments ($+/-M_{Ed}$; prerequisite is a XII-TKM G-G rib).

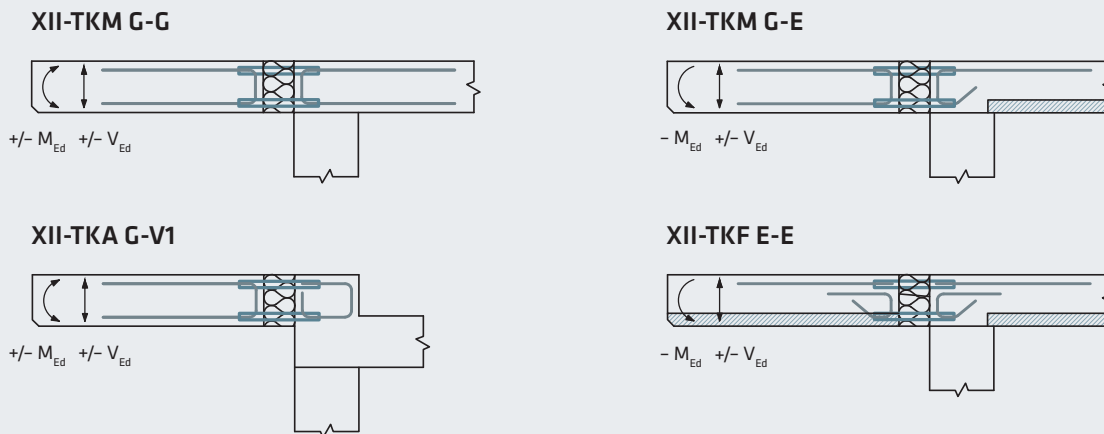

Fig. 25: Thermokorb load-bearing behaviour – transferable forces

BENDING MOMENTS AND SHEAR FORCES

MAXIMUM SHEAR RESISTANCE AND ASSOCIATED MOMENT RESISTANCE ACCORDING TO EUROCODE FOR XII-TKM AND XII-TKA

BCT*	Rib Height	Applied Force	Number of Ribs										
			1	2	3	4	5	6	7	8	9	10	
XII-TKM XII-TKA	≥ 160	110	M_{Rd} (kNm)	2.5	5.0	7.5	10.0	12.5	15.0	17.5	20.0	22.4	24.9
		$V_{Rd,max}$ (kN)	20.8	41.6	62.3	83.1	103.9	124.7	145.5	166.3	187.0	207.8	
	≥ 180	130	M_{Rd} (kNm)	2.5	5.0	7.6	10.1	12.6	15.1	17.6	20.2	22.7	25.2
		$V_{Rd,max}$ (kN)	21.0	42.0	63.0	84.0	105.0	126.0	147.0	168.0	189.0	210.0	
	≥ 200	150	M_{Rd} (kNm)	2.5	5.1	7.6	10.2	12.7	15.3	17.8	20.3	22.9	25.4
		$V_{Rd,max}$ (kN)	21.2	42.4	63.6	84.8	106.0	127.2	148.4	169.6	190.8	211.9	
	≥ 220	170	M_{Rd} (kNm)	2.6	5.1	7.7	10.3	12.8	15.4	17.9	20.5	23.1	25.6
		$V_{Rd,max}$ (kN)	21.4	42.7	64.1	85.5	106.8	128.2	149.6	170.9	192.3	213.7	
	≥ 240	190	M_{Rd} (kNm)	2.6	5.2	7.7	10.3	12.9	15.5	18.1	20.7	23.2	25.8
		$V_{Rd,max}$ (kN)	21.5	43.0	64.5	86.1	107.6	129.1	150.6	172.1	193.6	215.2	

When using the XII-TKA series, it should be noted that the V0 type is only available with a rib height of 110 mm. An adequate design value for bending and shear resistance in the connected reinforced concrete members must be verified by the structural designer in accordance with EC2.

MAXIMUM SHEAR RESISTANCE AND ASSOCIATED MOMENT RESISTANCE ACCORDING TO EUROCODE FOR XII-TKF

It should be noted that the XII-TKF series only has 50% of the shear force capacity of the XII-TKM series.

	BCT*	Rib Height	Applied Force	Number of Ribs									
	mm	mm		1	2	3	4	5	6	7	8	9	10
XII-TKF	≥ 180	130	M_{Rd} (kNm)	2.5	5.0	7.6	10.1	12.6	15.1	17.6	20.2	22.7	25.2
			$V_{Rd,max}$ (kN)	10.5	21.0	31.5	42.0	52.5	63.0	73.5	84.0	94.5	105.0
	≥ 200	150	M_{Rd} (kNm)	2.5	5.1	7.6	10.2	12.7	15.3	17.8	20.3	22.9	25.4
			$V_{Rd,max}$ (kN)	10.6	21.2	31.8	42.4	53.0	63.6	74.2	84.8	95.4	106.0
	≥ 220	170	M_{Rd} (kNm)	2.6	5.1	7.7	10.3	12.8	15.4	17.9	20.5	23.1	25.6
			$V_{Rd,max}$ (kN)	10.7	21.4	32.1	42.7	53.4	64.1	74.8	85.5	96.2	106.8
	≥ 240	190	M_{Rd} (kNm)	2.6	5.2	7.7	10.3	12.9	15.5	18.1	20.7	23.2	25.8
			$V_{Rd,max}$ (kN)	10.8	21.5	32.3	43.0	53.8	64.5	75.3	86.1	96.8	107.6

* Building Component Thickness

MAXIMUM MOMENT RESISTANCE AND ASSOCIATED SHEAR RESISTANCE ACCORDING TO EUROCODE FOR XII-TKM AND XII-TKA

	BCT*	Rib Height	Applied Force	Number of Ribs									
	mm	mm		1	2	3	4	5	6	7	8	9	10
XII-TKM XII-TKA V1 XII-TKA V2	≥ 160	110	$M_{Rd,max}$ (kNm) ¹	7.4	14.9	22.3	29.7	37.2	44.6	52.0	59.5	66.9	74.3
			V_{Rd} (kN)	14.9	29.8	44.7	59.6	74.5	89.4	104.3	119.2	134.1	149.0
	≥ 180	130	$M_{Rd,max}$ (kNm) ¹	8.9	17.9	26.8	35.7	44.7	53.6	62.5	71.5	80.4	89.4
			V_{Rd} (kN)	15.6	31.1	46.7	62.2	77.8	93.4	108.9	124.5	140.0	155.6
	≥ 200	150	$M_{Rd,max}$ (kNm) ¹	10.4	20.9	31.3	41.7	52.2	62.6	73.1	83.5	93.9	104.4
			V_{Rd} (kN)	15.2	30.4	45.6	60.7	75.9	91.1	106.3	121.5	136.7	151.8
	≥ 220	170	$M_{Rd,max}$ (kNm) ¹	11.9	23.9	35.8	47.8	59.7	71.6	83.6	95.5	107.4	119.4
			V_{Rd} (kN)	14.9	29.8	44.7	59.7	74.6	89.5	104.4	119.3	134.2	149.2
	≥ 240	190	$M_{Rd,max}$ (kNm) ¹	13.4	26.9	40.3	53.8	67.2	80.6	94.1	107.5	121.0	134.4
			V_{Rd} (kN)	14.7	29.4	44.2	58.9	73.6	88.3	103.0	117.7	132.5	147.2

* Building Component Thickness

MAXIMUM MOMENT RESISTANCE AND ASSOCIATED SHEAR RESISTANCE ACCORDING TO EUROCODE FOR XII-TKF

It should be noted that the XII-TKF series only has 50% of the shear force capacity of the XII-TKM series.

	BCT*	Rib Height	Applied Force	Number of Ribs									
	mm	mm		1	2	3	4	5	6	7	8	9	10
XII-TKF	≥ 180	130	$M_{Rd,max}$ (kNm)	8.9	17.9	26.8	35.7	44.7	53.6	62.5	71.5	80.4	89.4
			V_{Rd} (kN)	7.8	15.6	23.3	31.1	38.9	46.7	54.5	62.2	70.0	77.8
	≥ 200	150	$M_{Rd,max}$ (kNm)	10.4	20.9	31.3	41.7	52.2	62.6	73.1	83.5	93.9	104.4
			V_{Rd} (kN)	7.6	15.2	22.8	30.4	38.0	45.6	53.1	60.7	68.3	75.9
	≥ 220	170	$M_{Rd,max}$ (kNm)	11.9	23.9	35.8	47.8	59.7	71.6	83.6	95.5	107.4	119.4
			V_{Rd} (kN)	7.5	14.9	22.4	29.8	37.3	44.7	52.2	59.7	67.1	74.6
	≥ 240	190	$M_{Rd,max}$ (kNm)	13.4	26.9	40.3	53.8	67.2	80.6	94.1	107.5	121.0	134.4
			V_{Rd} (kN)	7.4	14.7	22.1	29.4	36.8	44.2	51.5	58.9	66.2	73.6

* Building Component Thickness

¹ When using a XII-TKA Thermokorb, $M_{Rd,max}$ only applies to versions V1 or V2 with up to 5 ribs per metre and with a sufficient number of stirrups provided on site (see Fig. 15, 16, 18, and 19).

INTERACTION DIAGRAMS

The diagrams can be used to determine the number of ribs required to transfer the applied forces. The diagrams apply to the type series XII-TKM, XII-TKA (V1 and V2) and XII-TKF. The shear resistance of the type series XII-TKM and XII-TKA (V1 and V2) are given on the left edge of the diagrams, and those for the type series XII-TKF are on the right edge of the diagrams.

For the type series XII-TKA in the V0 version (stirrup overhang 120 mm), the M-V curve only applies up to $V_{Rd,max}$. The variants V1 or V2 (stirrup overhang 170 or 220 mm, respectively) with a maximum of 5 ribs per metre can transfer larger bending moments (up to $M_{Rd,max}$). In this case, it must be ensured that a sufficient number of stirrups is provided on site (see type series XII-TKA, Fig. 15, 16, 18, and 19).

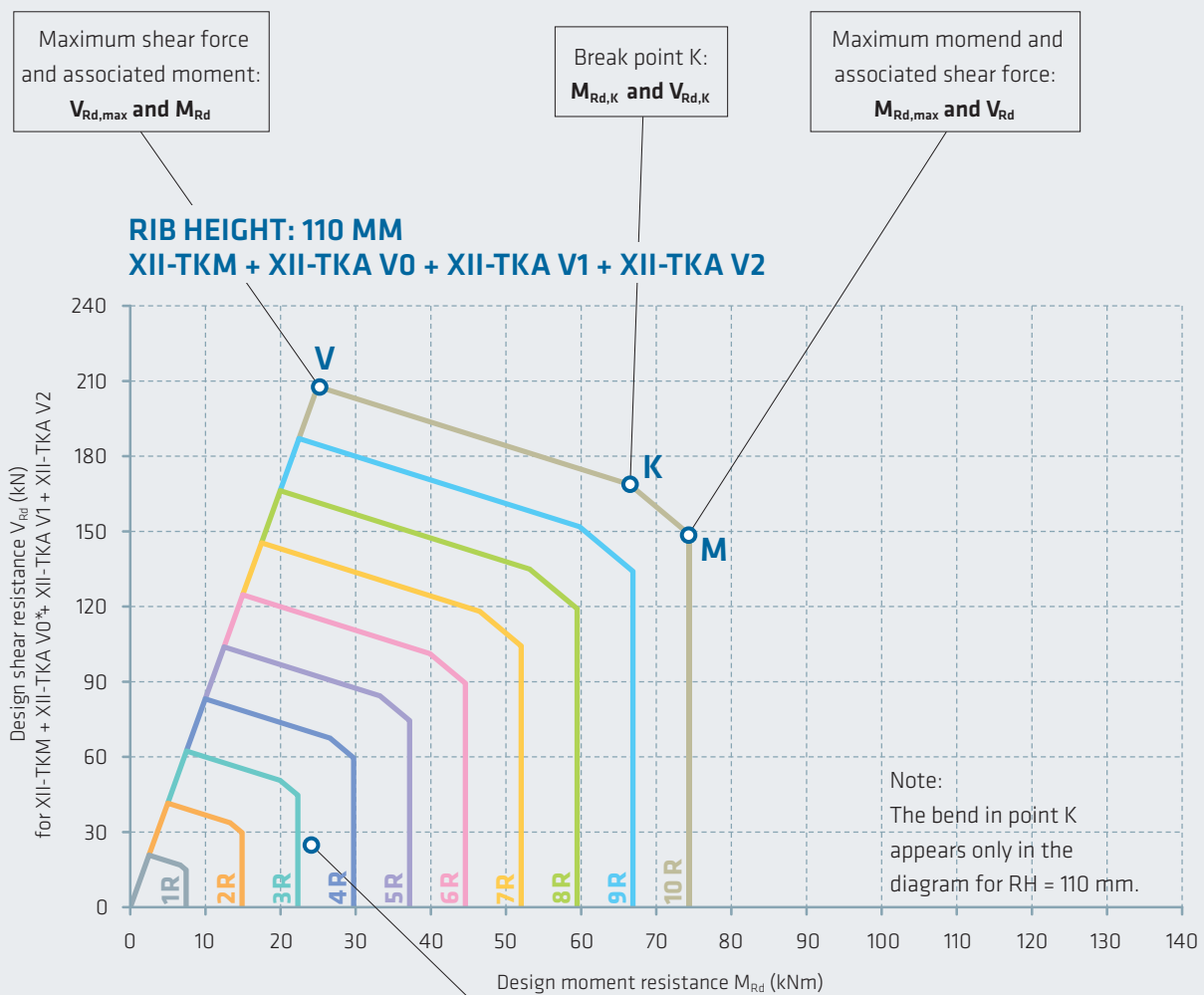

* for XII-TKA V0, and for XII-TKA V1 and V2 from 6 ribs per metre, the M-V curve only applies up to $V_{Rd,max}$

DESIGN EXAMPLE:

Thermokorb® XII-TK for a rectangular balcony (slab thickness $d = 160$ mm), with the following applied forces acc. to a FEM calculation:

$$M_{Ed} = -23.90 \text{ kNm/m} \quad V_{Ed} = 26.62 \text{ kN/m} \quad \rightarrow \quad \text{XII-TKM 4 G-G 11/16 R60}$$

RIB HEIGHT: 130 MM
XII-TKM + XII-TKA V1 + XII-TKA V2

XII-TKF

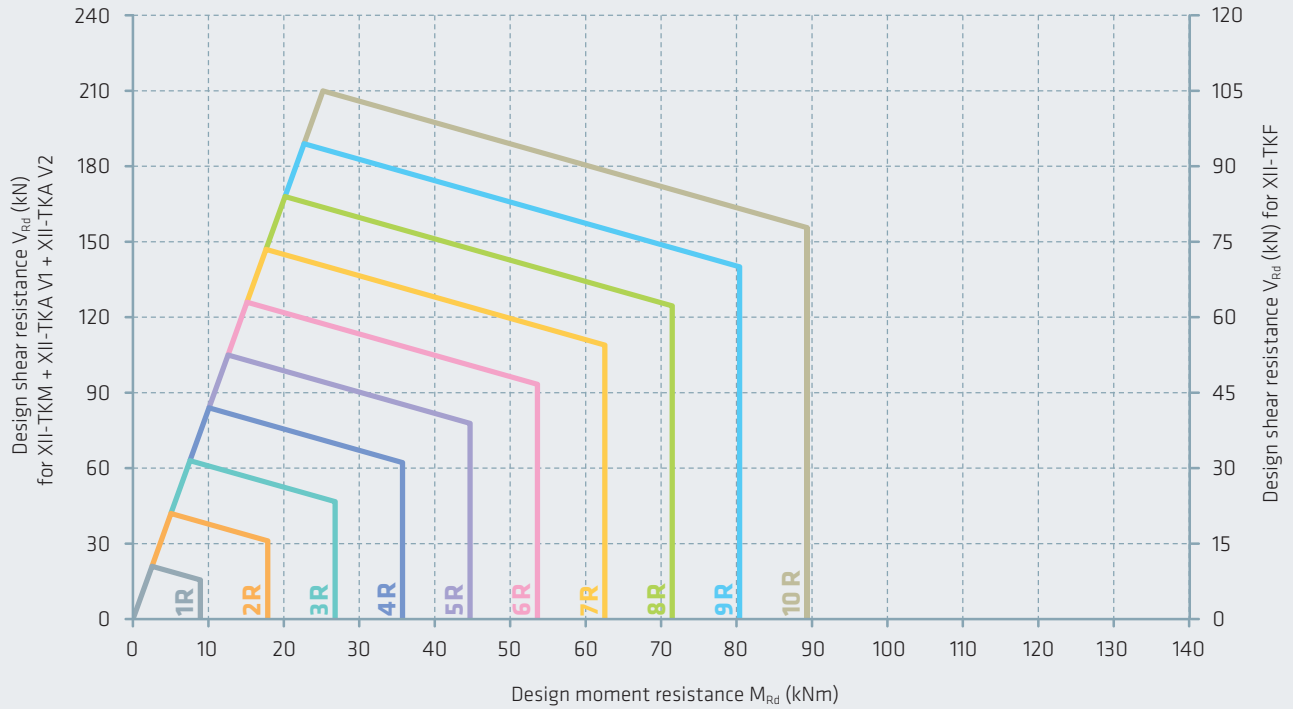

RIB HEIGHT: 150 MM
XII-TKM + XII-TKA V1 + XII-TKA V2

XII-TKF

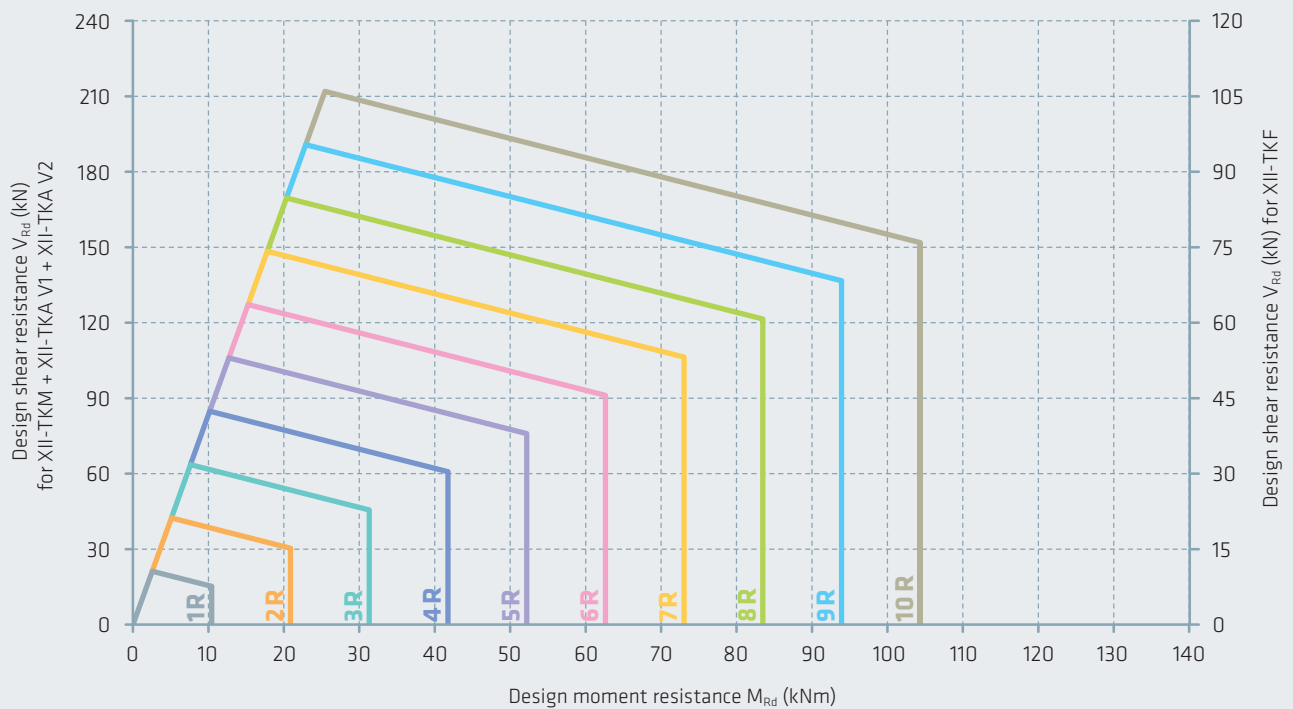

RIB HEIGHT: 170 MM
XII-TKM + XII-TKA V1 + XII-TKA V2

XII-TKF

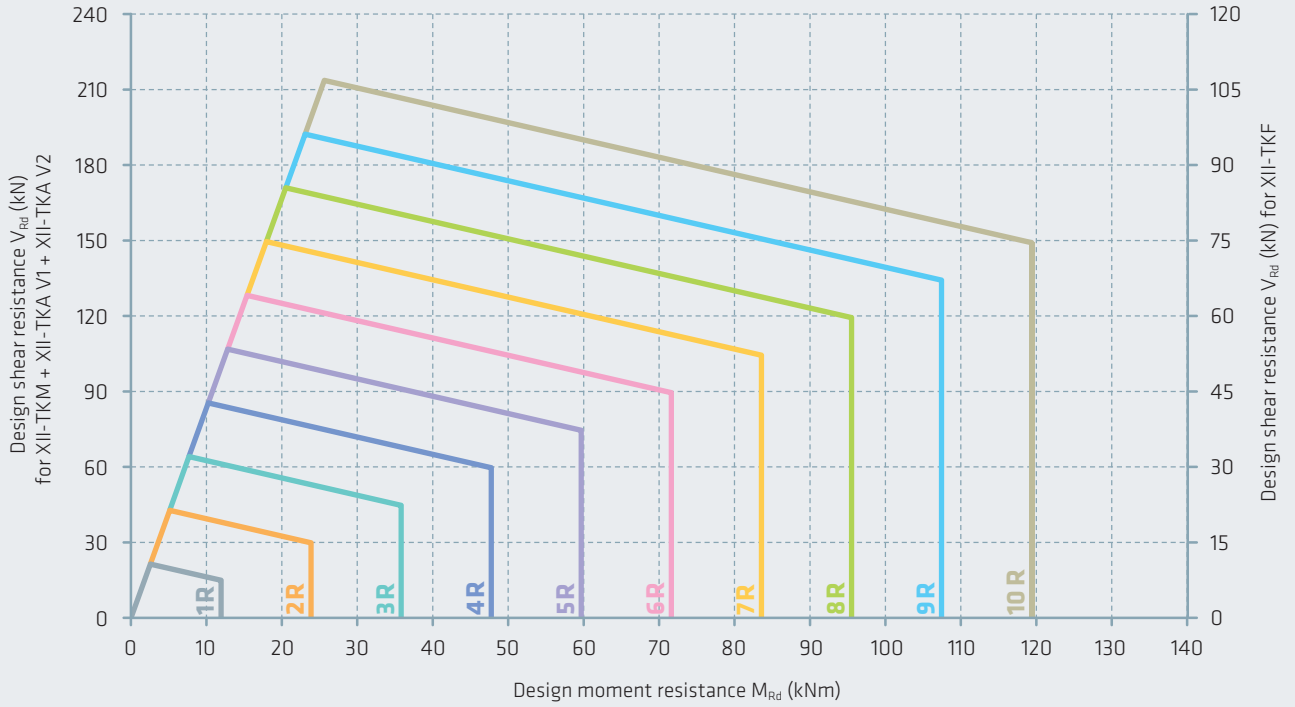

RIB HEIGHT: 190 MM
XII-TKM + XII-TKA V1 + XII-TKA V2

XII-TKF

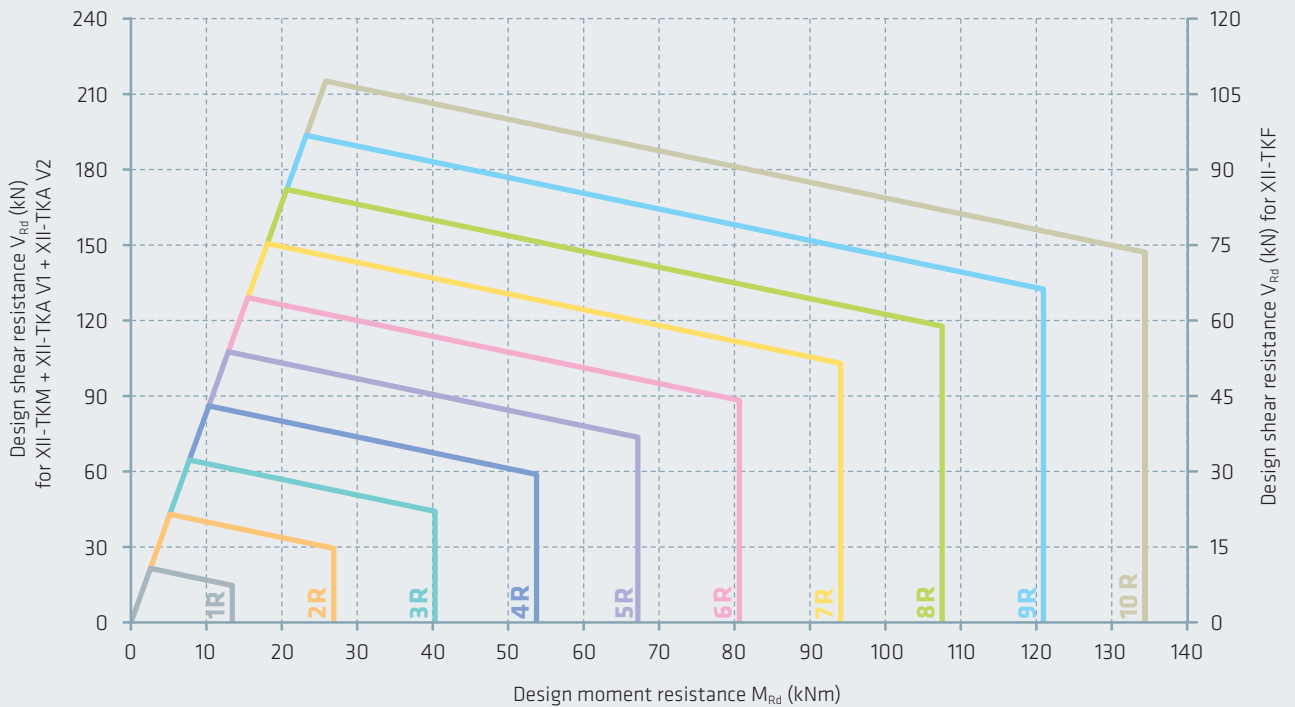

RECOMMENDED ADDITIONAL CAMBER

The high moment of inertia of the individual ribs has a very favourable effect on the deformation and vibration behaviour of the Thermokorb® XII-TK.

In order to limit the total deflection of the balcony slab, it is recommended to design the balcony with a camber. It is important to pay attention to the drainage direction of the balcony.

The deflection of the balcony slab consists of the portion due to the rotation of the Thermokorb® XII-TK (c_{TK}), and the deflection of the concrete slab (c_{Conc}). The following table can be used to calculate the share of the Thermokorb® XII-TK in the deflection of cantilevered rectangular balconies. The share resulting from the deflection of the concrete slab must be determined by the structural designer.

$$c_{tot} = c_{TK} + c_{Conc}$$

c_{TK} Camber due to deformation of the Thermokorb® XII-TK
 c_{Conc} Camber due to deformation of the balcony slab

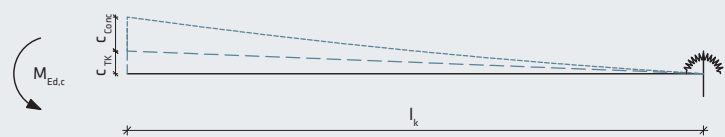

Fig. 26: Camber of a balcony slab

RECOMMENDED ADDITIONAL CAMBER AS A PERCENTAGE OF THE CANTILEVER LENGTH

Building Component Thickness	Rib Height RH	Rotation ϕ
mm	mm	%
≥ 160	110	0.57 %
≥ 180	130	0.46 %
≥ 200	150	0.39 %
≥ 220	170	0.33 %
≥ 240	190	0.29 %

The indicated table values of rotation as a percentage of the cantilever length result from the deformation of the Thermokorb® XII-TK in the serviceability limit state. These are recommended guide values. The total camber c_{tot} to be applied to the balcony slab results from the portion of the Thermokorb® XII-TK (c_{TK}) and the deflection of the reinforced concrete slab (c_{Conc}) based on EC2 (EN 1992-1-1 and the Austrian National Annex ÖNORM B 1992-1-1).

Additional camber c_{TK} resulting from the deformation of the Thermokorb® XII-TK:

$$c_{TK} = l_k \cdot \frac{\phi}{100} \cdot \frac{M_{Ed,c}}{M_{Rd,max}}$$

For the load case combination (ULS) used to determine the additional camber of the slab, it is recommended to consider the full dead load plus 50% of the variable load. The load case combination for the calculation of the deflection can be defined by the structural designer.

l_k Cantilever length

ϕ Rotation in % - see table

$M_{Ed,c}$ Decisive bending moment in kNm/m in ultimate limit state for „g+q/2“

$M_{Rd,max}$ Maximum design moment resistance of the Thermokorb® XII-TK in kNm/m (see tables on pages 18 and 19)

STANDARD DESIGN

DESCRIPTION

The length of the standard design of a Thermokorb® XII-TK is 1000 mm. The Thermokorb® XII-TK is optionally available with fire protection panels at the top and bottom (REI120) or with all-round fire protection panels (REI120-U). The version with all-round fire protection panels (REI120-U) is 30 mm longer.

XII-TKM 2 | XII-TKA 2

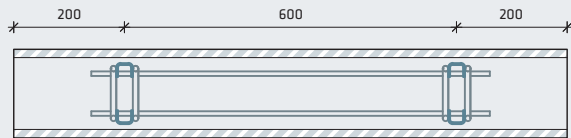

XII-TKM 3 | XII-TKA 3

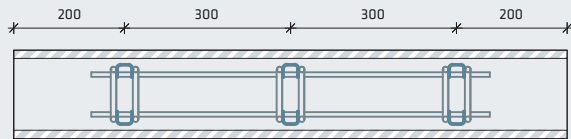

XII-TKM 4 | XII-TKA 4

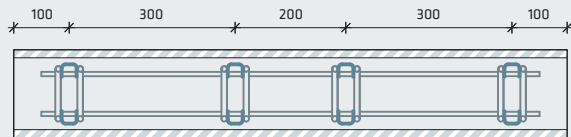

XII-TKM 5 | XII-TKA 5

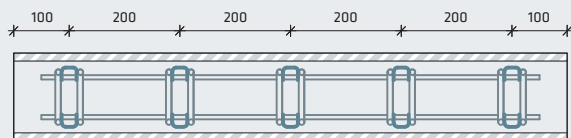

XII-TKM 6 | XII-TKA 6

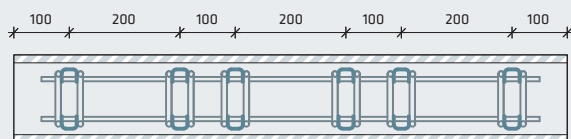

Explanation of the length of a Thermokorb® XII-TK without/with fire-proofing panels R60/REI120/REI120-U

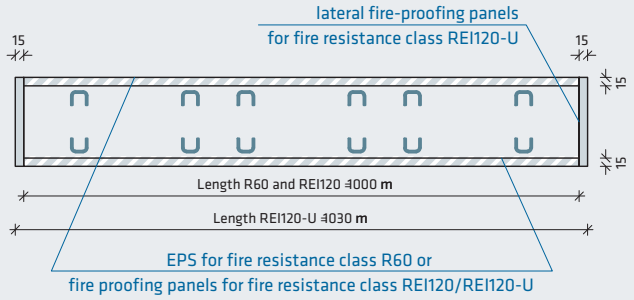

XII-TKM 7 | XII-TKA 7

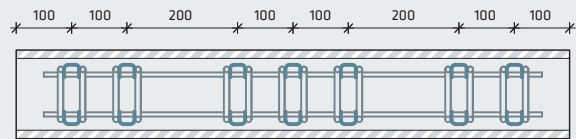

XII-TKM 8 | XII-TKA 8

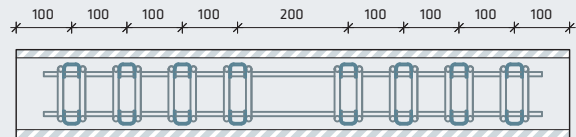

XII-TKM 9 | XII-TKA 9

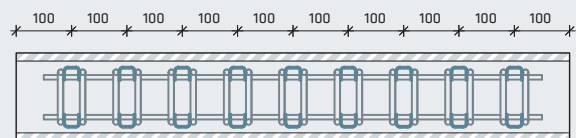

XII-TKM 10 | XII-TKA 10

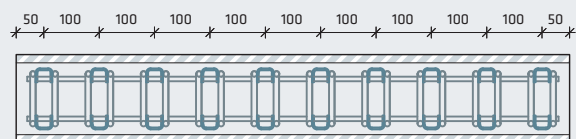

RIB DESIGN

DESCRIPTION

The length of the rib design of a Thermokorb® XII-TK depends on the required number of ribs ($l = n \times 100 \text{ mm}$). The Thermokorb® XII-TK is optionally available with fire protection panels at the top and bottom (REI120) or with all-round fire protection panels (REI120-U). The version with all-round fire protection panels (REI120-U) is 30 mm longer.

Explanation of the length of a Thermokorb® XII-TK without/with fire-proofing panels R60/REI120/REI120-U

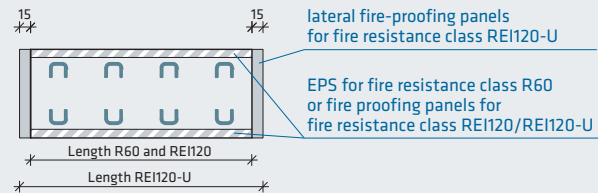

XII-TKM R1 | XII-TKA R1

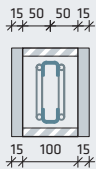

XII-TKM R2 | XII-TKA R2

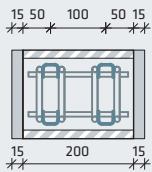

XII-TKM R3 | XII-TKA R3

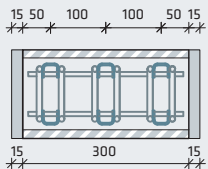

XII-TKM R4 | XII-TKA R4

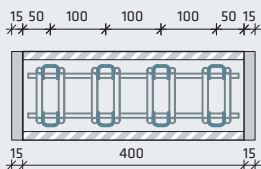

XII-TKM R5 | XII-TKA R5

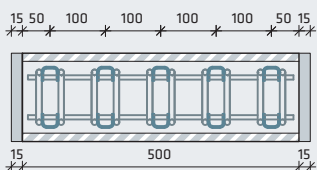

XII-TKM R6 | XII-TKA R6

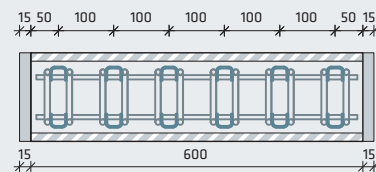

XII-TKM R7 | XII-TKA R7

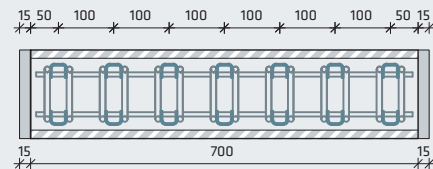

XII-TKM R8 | XII-TKA R8

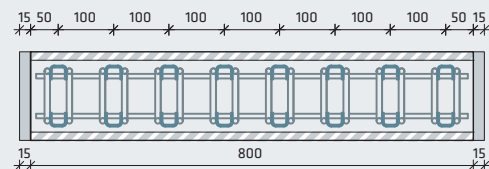

XII-TKM R9 | XII-TKA R9

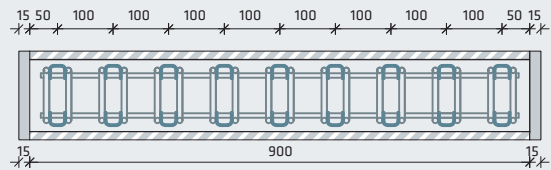

BUILDING PHYSICS - THERMAL INSULATION VALUES

The use of Thermokorb® XII-TK for thermal insulation reduces heat losses which arise from material-based and geometric thermal bridges. Uninsulated joint areas may also lead to a considerable lowering of the surface temperature of the building component and increase the risk of condensation and mould formation. The use of Thermokorb® XII-TK provides a good heat distribution pattern and heating cost savings.

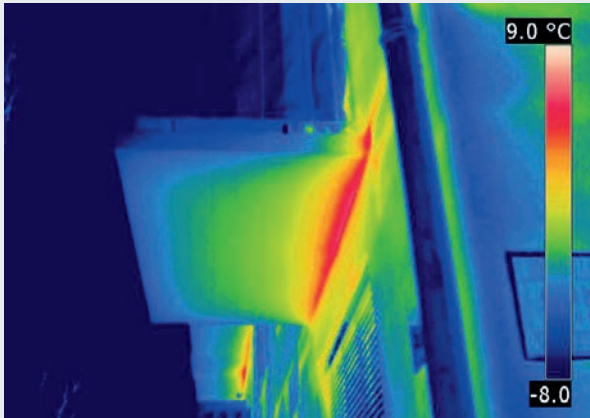

Fig. 27: Uninsulated connection area

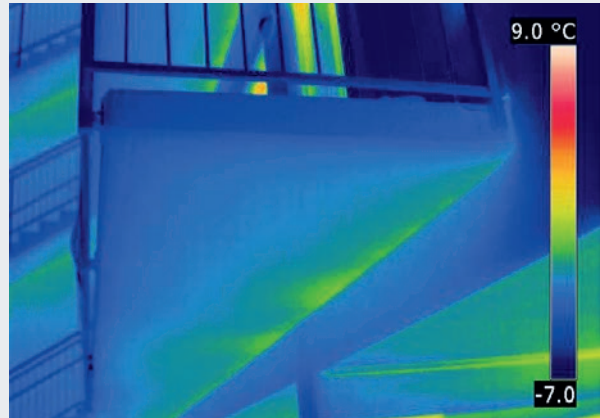

Fig. 28: Connection area with Thermokorb® TK

Note: The values given are based on a simplified one-dimensional calculation. The values for the version REI120-U with all-round fire protection boards are available for download at www.avi.at.



Thermal insulation values of all fire protection versions can be found on our website www.avi.at

THERMOKORB® XII-TK - STANDARD DESIGN

FIRE RESISTANCE CLASS R60

* BCT = Building Component Thickness

BCT*	Rib Height		Number of Ribs									
			2	3	4	5	6	7	8	9	10	
mm	mm											
160	110	λ_{eq} (W/mK)	0.136	0.189	0.241	0.294	0.346	0.399	0.451	0.504	0.556	
		R_{eq} (m ² K/W)	0.882	0.637	0.498	0.409	0.347	0.301	0.266	0.238	0.216	
180	130	λ_{eq} (W/mK)	0.124	0.171	0.218	0.264	0.311	0.358	0.404	0.451	0.498	
		R_{eq} (m ² K/W)	0.965	0.702	0.551	0.454	0.386	0.335	0.297	0.266	0.241	
200	150	λ_{eq} (W/mK)	0.115	0.157	0.199	0.241	0.283	0.325	0.367	0.409	0.451	
		R_{eq} (m ² K/W)	1.043	0.764	0.603	0.498	0.424	0.369	0.327	0.293	0.266	
220	170	λ_{eq} (W/mK)	0.107	0.146	0.184	0.222	0.260	0.298	0.336	0.375	0.413	
		R_{eq} (m ² K/W)	1.118	0.824	0.653	0.541	0.461	0.402	0.357	0.320	0.291	
240	190	λ_{eq} (W/mK)	0.101	0.136	0.171	0.206	0.241	0.276	0.311	0.346	0.381	
		R_{eq} (m ² K/W)	1.188	0.882	0.702	0.582	0.498	0.435	0.386	0.347	0.315	
250	190	λ_{eq} (W/mK)	0.098	0.132	0.165	0.199	0.233	0.266	0.300	0.333	0.367	
		R_{eq} (m ² K/W)	1.222	0.910	0.725	0.603	0.516	0.451	0.400	0.360	0.327	

FIRE RESISTANCE CLASS REI120

* BCT = Building Component Thickness

BCT*	Rib Height		Number of Ribs								
			2	3	4	5	6	7	8	9	10
mm	mm										
160	110	λ_{eq} (W/mK)	0.170	0.222	0.275	0.327	0.380	0.432	0.485	0.537	0.590
		R_{eq} (m ² K/W)	0.708	0.540	0.437	0.367	0.316	0.278	0.248	0.223	0.204
180	130	λ_{eq} (W/mK)	0.154	0.201	0.248	0.294	0.341	0.388	0.434	0.481	0.528
		R_{eq} (m ² K/W)	0.778	0.597	0.485	0.408	0.352	0.310	0.276	0.250	0.227
200	150	λ_{eq} (W/mK)	0.142	0.184	0.226	0.268	0.310	0.352	0.394	0.436	0.478
		R_{eq} (m ² K/W)	0.846	0.653	0.531	0.448	0.387	0.341	0.305	0.275	0.251
220	170	λ_{eq} (W/mK)	0.132	0.170	0.208	0.246	0.285	0.323	0.361	0.399	0.437
		R_{eq} (m ² K/W)	0.911	0.706	0.577	0.487	0.422	0.372	0.333	0.301	0.274
240	190	λ_{eq} (W/mK)	0.123	0.158	0.193	0.228	0.263	0.298	0.333	0.368	0.403
		R_{eq} (m ² K/W)	0.973	0.758	0.621	0.525	0.456	0.402	0.360	0.326	0.297
250	190	λ_{eq} (W/mK)	0.120	0.153	0.187	0.220	0.254	0.288	0.321	0.355	0.389
		R_{eq} (m ² K/W)	1.003	0.783	0.642	0.544	0.472	0.417	0.373	0.338	0.309

THERMOKORB® XII-TK - RIB DESIGN

FIRE RESISTANCE CLASS R60

* BCT = Building Component Thickness

BCT*	Rib Height		Number of Ribs										
			1	2	3	4	5	6	7	8	9	AT 2	
mm	mm												
160	110	λ_{eq} (W/mK)	0.556	0.556	0.556	0.556	0.556	0.556	0.556	0.556	0.556	0.556	0.381
		R_{eq} (m ² K/W)	0.216	0.216	0.216	0.216	0.216	0.216	0.216	0.216	0.216	0.216	0.315
180	130	λ_{eq} (W/mK)	0.498	0.498	0.498	0.498	0.498	0.498	0.498	0.498	0.498	0.498	0.342
		R_{eq} (m ² K/W)	0.241	0.241	0.241	0.241	0.241	0.241	0.241	0.241	0.241	0.241	0.351
200	150	λ_{eq} (W/mK)	0.451	0.451	0.451	0.451	0.451	0.451	0.451	0.451	0.451	0.451	0.311
		R_{eq} (m ² K/W)	0.266	0.266	0.266	0.266	0.266	0.266	0.266	0.266	0.266	0.266	0.386
220	170	λ_{eq} (W/mK)	0.413	0.413	0.413	0.413	0.413	0.413	0.413	0.413	0.413	0.413	0.286
		R_{eq} (m ² K/W)	0.291	0.291	0.291	0.291	0.291	0.291	0.291	0.291	0.291	0.291	0.420
240	190	λ_{eq} (W/mK)	0.381	0.381	0.381	0.381	0.381	0.381	0.381	0.381	0.381	0.381	0.264
		R_{eq} (m ² K/W)	0.315	0.315	0.315	0.315	0.315	0.315	0.315	0.315	0.315	0.315	0.454
250	190	λ_{eq} (W/mK)	0.367	0.367	0.367	0.367	0.367	0.367	0.367	0.367	0.367	0.367	0.255
		R_{eq} (m ² K/W)	0.327	0.327	0.327	0.327	0.327	0.327	0.327	0.327	0.327	0.327	0.471

FIRE RESISTANCE CLASS REI120

* BCT = Building Component Thickness

BCT*	Rib Height		Number of Ribs										
			1	2	3	4	5	6	7	8	9	AT 2	
mm	mm												
160	110	λ_{eq} (W/mK)	0.590	0.590	0.590	0.590	0.590	0.590	0.590	0.590	0.590	0.590	0.415
		R_{eq} (m ² K/W)	0.204	0.204	0.204	0.204	0.204	0.204	0.204	0.204	0.204	0.204	0.289
180	130	λ_{eq} (W/mK)	0.528	0.528	0.528	0.528	0.528	0.528	0.528	0.528	0.528	0.528	0.372
		R_{eq} (m ² K/W)	0.227	0.227	0.227	0.227	0.227	0.227	0.227	0.227	0.227	0.227	0.323
200	150	λ_{eq} (W/mK)	0.478	0.478	0.478	0.478	0.478	0.478	0.478	0.478	0.478	0.478	0.338
		R_{eq} (m ² K/W)	0.251	0.251	0.251	0.251	0.251	0.251	0.251	0.251	0.251	0.251	0.355
220	170	λ_{eq} (W/mK)	0.437	0.437	0.437	0.437	0.437	0.437	0.437	0.437	0.437	0.437	0.310
		R_{eq} (m ² K/W)	0.274	0.274	0.274	0.274	0.274	0.274	0.274	0.274	0.274	0.274	0.387
240	190	λ_{eq} (W/mK)	0.403	0.403	0.403	0.403	0.403	0.403	0.403	0.403	0.403	0.403	0.287
		R_{eq} (m ² K/W)	0.297	0.297	0.297	0.297	0.297	0.297	0.297	0.297	0.297	0.297	0.419
250	190	λ_{eq} (W/mK)	0.389	0.389	0.389	0.389	0.389	0.389	0.389	0.389	0.389	0.389	0.276
		R_{eq} (m ² K/W)	0.309	0.309	0.309	0.309	0.309	0.309	0.309	0.309	0.309	0.309	0.434

SPACING OF EXPANSION JOINTS

The maximum spacing of expansion joints for a cantilevered rectangular balcony without additional support is to be limited to $s_{\text{joint}} = 12\text{ m}$. A larger spacing of expansion joints causes horizontal deformations due to temperature changes. In the case of balconies with two or more edges supported by Thermokorb® elements (recessed balcony, outside or inside corner balcony), the dimensions of the balcony

without an expansion joint must not exceed $s_{\text{joint}}/2 = 6\text{ m}$. To avoid different deflections of the balconies, shear dowels are to be arranged in the expansion joints. The expansion joint spacing is to be determined by the structural designer. Depending on the loading and the installation situation, a larger spacing for expansion joints can be specified in coordination with the Technical Service of AVI.

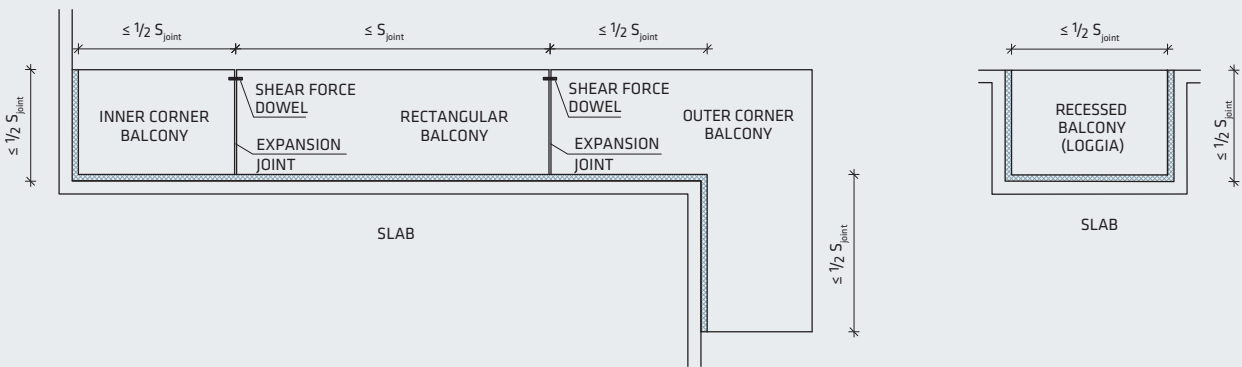

Fig. 29: Spacing of expansion joints

CORNER DESIGN WITH THE THERMOKORB® XII-TK

By using Thermokorb® XII-TK with different rib heights, collisions in corner areas can easily be avoided.

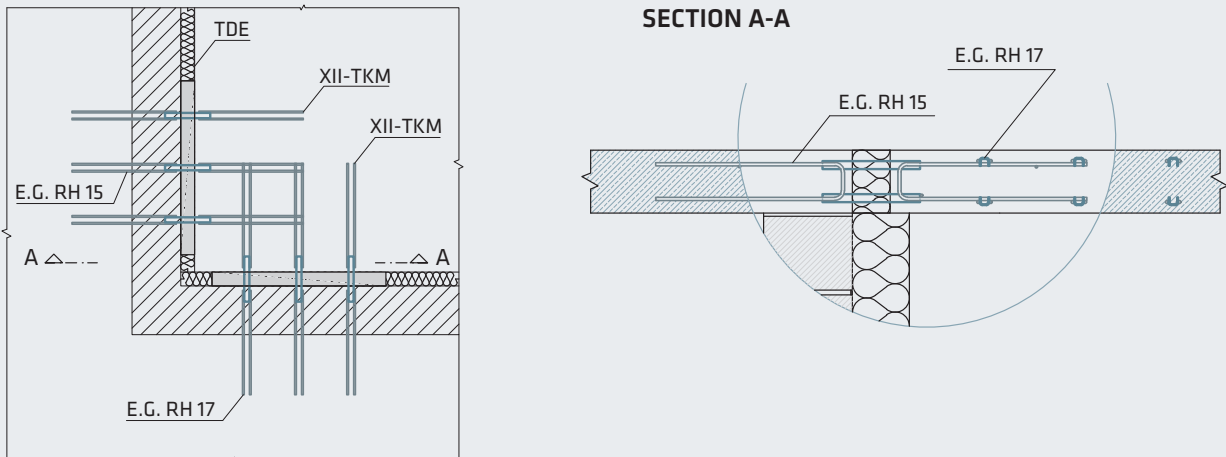
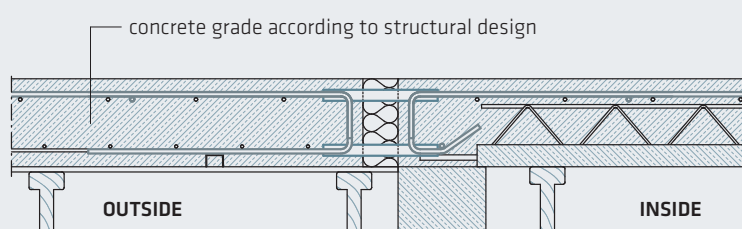
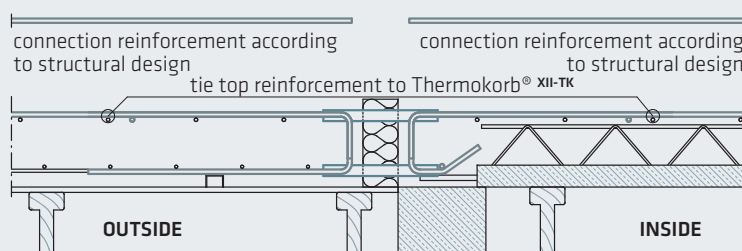
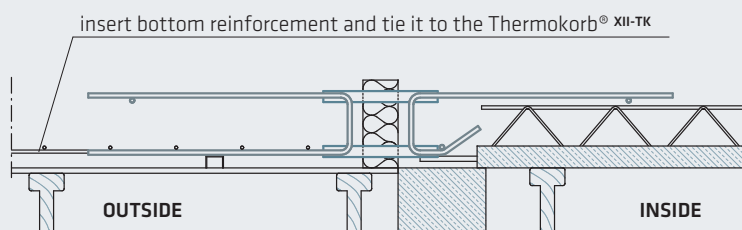
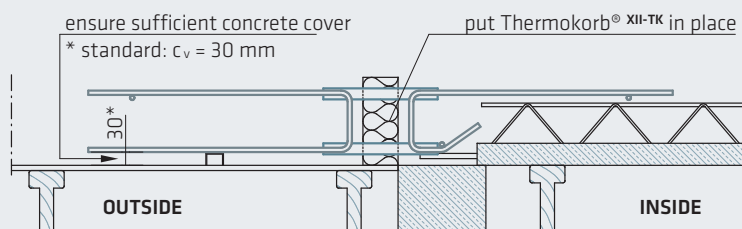
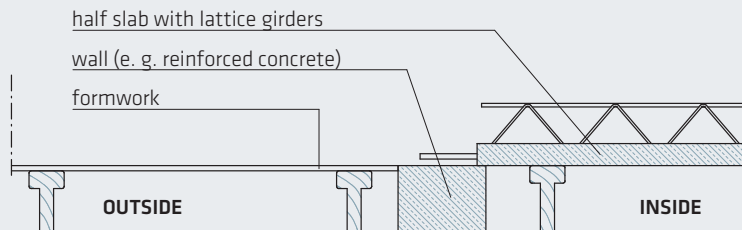

Fig. 30: Corner design with the Thermokorb® XII-TK

INSTALLATION INSTRUCTIONS

Example: XII-TKM G-E



1. Formwork

The formwork of the entire slab has to be erected before placing a Thermokorb® XII-TK. Required camber should be made in the formwork, as well. If half slabs are used, they also have to be placed before.

2. Thermokorb® XII-TK

When placing a Thermokorb® XII-TK, the required concrete cover has to be achieved. The standard concrete cover of U-stirrups of a Thermokorb® XII-TK is at least 30mm. The Thermokorb® XII-TK has to be placed in its correct location according to construction drawings and/or affixed labels.

3. Bottom Reinforcement

In order to ensure the required concrete cover, the bottom reinforcement has to be placed on top of the bottom legs of the U-stirrups of the Thermokorb® XII-TK.

4. Top Reinforcement

Outside and inside connection reinforcement acc. to structural design. This reinforcement can be placed in the form of straight rebars, stirrups, or reinforcing wire mesh.

5. Concrete

In order to ensure that the Thermokorb® XII-TK stays in place during concreting, it is essential to pour and vibrate the concrete evenly. It is also recommended to secure the Thermokorb® XII-TK in place.

OVERVIEW PRODUCT FAMILY THERMOKORB®

THERMOKORB® TK

The load-bearing thermal insulation element between inside and outside components with an insulation thickness of 80 mm

Main areas of application:

- freely cantilevered balcony slabs
- continuous slabs (indirect support)
- special solutions: e.g.
 - level changes
 - connections of cantilevered slabs to walls
 - wall connections

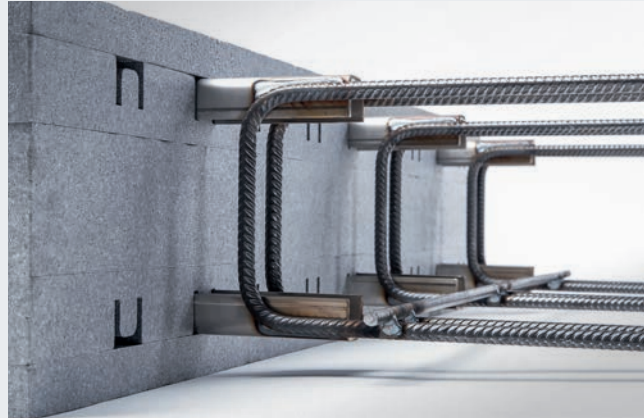

THERMOKORB® TKQ

The load-bearing thermal insulation element for shear loads with an insulation thickness of 80 mm

Main areas of application:

- supported balconies
- supported access balconies
- recessed balconies



THERMOKORB® SL-TK

The load-bearing thermal insulation element between inside and outside components with an insulation thickness of 80 mm for high loads

Main areas of application:

- freely cantilevered balcony slabs
- continuous slabs (indirect support)
- special solutions: e.g.
 - wall connections





All information about the AVI products can be found on our website www.avi.at

THERMOKORB® TK+LIFT

AVI Thermokorb® TK + Philipp threaded transport anchor with an insulation thickness of 80 mm

Main areas of application:

- freely cantilevered precast balconies
- continuous slabs (indirect support) made of precast concrete

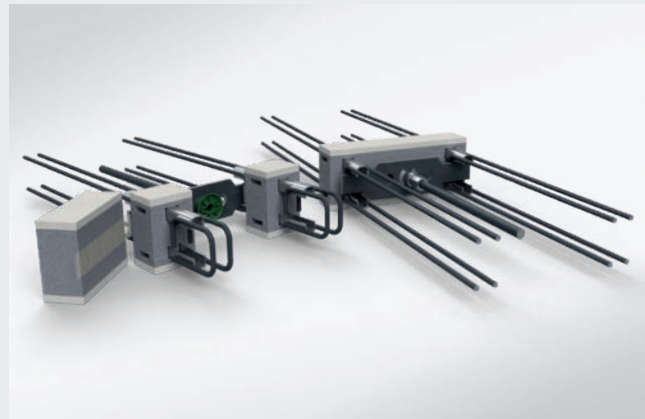

THERMOKORB® XII-TK

The load-bearing thermal insulation element between inside and outside components with an increased insulation thickness of 120 mm

Main areas of application:

- freely cantilevered balcony slabs
- continuous slabs (indirect support)
- special solutions: e.g.
 - level changes
 - connections of cantilevered slabs to walls
 - wall connections



THERMO INSULATION ELEMENT TDE

The non-load-bearing insulation element for thermally separated areas with an insulation thickness of 80 mm and 120 mm.

Main areas of application:

- filler insulating element
- edge insulation element



AVI

WWW.AVI.AT

Please direct your inquiries about availability and price of products to our sales department.
Please direct technical inquiries to the Technical Service of AVI (support@avi.at).

ALPENLÄNDISCHE VEREDELUNGS-INDUSTRIE
GESELLSCHAFT M.B.H.
Gustinus-Ambrosi-Straße 1-3
8074 Raaba-Grambach/Austria
T +43 316 4005-0
F +43 316 4005-507
verkauf@avi.at
www.avi.at

You can also find us on:



The content of this brochure has been created with the utmost care. Nevertheless, mistakes, inaccuracies, and typographical and printing errors are reserved. Technical changes are possible. Only the current brochure is valid (www.avi.at). The information in this brochure may be used by qualified persons only, taking into account the constraints of the project.